

PhD Thesis

Homotopical algebra and combinatorics of polytopes

Daria Poliakova

Advisor: Lars Hesselholt
Co-advisor: Ryszard Nest

Submitted: August 8, 2021

This thesis has been submitted to the PhD School of The Faculty of Science, University of Copenhagen

Preface

Author:

Daria Poliakova, University of Copenhagen (email: polydarya@gmail.com)

Advisor:

Lars Hesselholt, University of Copenhagen

Co-advisor:

Ryszard Nest, University of Copenhagen

Assessment Committee:

Prof. Nathalie Wahl, (chair) University of Copenhagen

Prof. Vladimir Dotsenko, Université de Strasbourg

Prof. Vladimir Baranovsky, University of Illinois, Chicago

Submitted for assessment:

August 8, 2021

ISBN:

978-87-7125-045-9

Contents

I	Introduction	6
	Overview of areas	7
	DG-categories	7
	Operads	8
	Polyhedra	10
	Questions addressed in this thesis	11
	Structure of this thesis	15
	Acknowledgements	16
II	Papers	21
1	A note on a Holstein construction	22
	1.1 Introduction	22
	1.2 Homotopy theory of DG-categories	24
	1.2.1 Dwyer-Kan model structure for DG-categories	24
	1.2.2 A_∞ functors as inner Hom	24
	1.2.3 Reedy model structure for diagrams	26
	1.3 Reedy fibrant replacement for simplicial DG-categories	28
	1.3.1 Holstein construction	28
	1.3.2 Quasiequivalences	29
	1.3.3 Reedy fibrancy	31
	1.A An alternative proof of Reedy fibrancy	33
	1.A.1 Contraction of cones and pretriangulated envelopes	34
	1.A.2 Proof of Theorem 1.3.10	35
	1.B Erratum	35
2	Homotopy characters as a homotopy limit	38
	2.1 Introduction	38
	2.2 Preliminaries	40
	2.2.1 Model categories involved	40
	2.2.2 DG-modules	40
	2.2.3 Cobar-constructions	40
	2.3 The cosimplicial system	41

2.4	Maurer-Cartan elements in Cobar	44
2.5	CoMorita equivalences	45
2.6	Homotopy characters	48
2.7	Tensor products and multibraces	50
2.A	Homotopy limit in DG-algebras	53
2.A.1	Simplicial resolutions in $DGVect(k)$	54
2.A.2	Simplicial resolutions in $DGAlg(k)$	56
2.A.3	Fat totalizations in $DGVect(k)$ and $DGAlg(k)$	57
2.A.4	Application to the cosimplicial system of a DG-bialgebra	58
3	Cellular chains on freehedra and operadic pairs	60
3.1	Introduction	60
3.1.1	Organization of the paper	61
3.1.2	Acknowledgements	61
3.2	Operads and operadic pairs	62
3.3	Associahedra and multiplihedra	69
3.3.1	Associahedra	69
3.3.2	Multiplihedra	70
3.3.3	Contraction problem	73
3.4	Freehedra	74
3.4.1	Freehedra as truncations of simplices	74
3.4.2	Freehedra as subdivisions of cubes	76
3.4.3	Freehedra combinatorially	78
3.5	Main isomorphism	80
3.6	Projections of polyhedra	82
3.7	Hopf operadic pairs	84
III	Projects	87
4	Colored operads from directed polytopes	88
4.1	Colored operads, Poincaré-Hilbert endomorphisms and duality	88
4.1.1	Generalities	88
4.1.2	Series inversion	90
4.1.3	Koszul duality	93
4.2	Main construction	95
4.3	Functoriality	97
4.4	Simplices and cubes	98
4.5	Polygons	104
4.6	Shortness and integrated A_∞ -coalgebras	112

5	Constrainahedra	115
5.1	Main definition	115
5.1.1	Good rectangular preorders	115
5.1.2	Anna & Bob metaphor for preorders	118
5.1.3	Associated rectangular bracketings	120
5.2	Constrainahedra are lattices	122
5.3	Convex hull realization	126

Part I

Introduction

We begin by giving a short overview of mathematical areas that intersect in this thesis. We continue by presenting the questions studied in this thesis. We conclude by outlining the structure of this thesis.

Overview of areas

DG-categories

DG categories, since their theory was developed by Keller [Kel1], are a powerful tool to study various invariants in algebraic geometry and representation theory. Historically those invariants were discussed in the language of triangulated categories. For a scheme/variety X , one can study the derived category of quasicoherent sheaves $D(\mathrm{QCoh}(X))$, or the bounded derived category of coherent sheaves $D^b(\mathrm{Coh}(X))$, or the category of perfect objects $\mathrm{Perf}(X)$ (which would coincide with $D^b(\mathrm{Coh}(X))$ in the smooth case but not in the general case), and so on. However, the axiomatics of triangulated categories has some limitations:

- Cones in triangulated categories are not functorial.
- For two triangulated categories, there is no reasonable triangulated category of functors.

To combat this, Bondal and Kapranov developed the theory of pretriangulated DG-categories and DG-enhancements [BK]. Recall that a DG-category is simply a category enriched in chain complexes rather than sets/groups. For any DG category \mathcal{C} , there is an associated homotopy category $\mathrm{Ho}(\mathcal{C})$ obtained by passing to homology of every Hom . Also, one can consider left and right DG-modules over \mathcal{C} : these are respectively covariant and contravariant DG-functors from \mathcal{C} to the DG-category of chain complexes.

Definition. For a triangulated category \mathcal{T} , its *DG-enhancement* is a DG-category \mathcal{C} with a triangulated equivalence $\mathrm{Ho}(\mathcal{C}) \simeq \mathcal{T}$. The triangulated structure on $\mathrm{Ho}(\mathcal{C})$ is obtained by Yoneda-embedding into the category of right DG-modules over \mathcal{C} (the term "pretriangulated" precisely means that the image of the Yoneda embedding is a triangulated subcategory).

Note that in an enhanced triangulated category, cones are already functorial; also note that unlike the category of triangulated categories, the category of DG-categories comes equipped with an inner Hom (and also with a homotopy version of it, see Toen [Toe] or Faonte [Fao2]). Since the discovery of DG-enhancements, the language of DG categories has become a major framework for homological algebra and derived algebraic geometry. Many

interesting triangulated categories were shown to admit a DG-enhancement that is unique up to a quasiequivalence of DG-categories ([LO], [LS]).

This brings the natural question about the category of DG-categories with their weak equivalences, which became the title of a famous paper by Tamarkin: “What do DG categories form?” [Tam1]. One of the earliest answers was obtained by Tabuada [Tab] (in fact, earlier than Tamarkin’s formulation of the question appeared):

Theorem. The category $\mathrm{DGCat}(\mathbf{k})$ admits the structure of a *model category* where the weak equivalences are the quasiequivalences.

This makes the whole toolkit of Hovey [Hov] and Hirschhorn [Hir] available. Explicit computations in the model category $\mathrm{DGCat}(\mathbf{k})$ often use a slightly more general A_∞ -language (introduced by Stasheff in [Sta] and developed in numerous works by other people). This is the approach taken in this thesis.

Before closing this subsection, one should probably comment on the interplay between the world of DG-categories and the modern world of ∞ -categories. The originally mentioned issues in triangulated categories admit an alternative solution: one can consider *stable $(\infty, 1)$ -categories* which can also enhance triangulated categories in the sense that for a stable $(\infty, 1)$ -category, its homotopy category comes equipped with a natural triangulated structure. In Higher Algebra [Lur], Lurie describes the construction of the DG-nerve that forms an ∞ -category from a DG-category. It was proved by Faonte in [Fao1] that a DG-nerve of a pretriangulated DG-category is a stable ∞ -category. Using the language of DG-categories in this thesis gives away the author’s old-fashioned liking for small models and explicit formulas.

Operads

Operads appeared in mathematics in the early seventies ([BV], [May]) to study algebraic operations without fixing the space on which these operations act. Formally, for any symmetric monoidal category \mathbf{C} with sums, one has a non-symmetric monoidal category of (colored) \mathbb{N} -sequences in \mathbf{C} , and a (colored) operad is an algebra in this latter category. Colored operads generalize monoidal categories: one can view operations of higher arity as multi-hom functors that do not necessarily have a representing object. In this way, colored DG-operads provide a homotopy-coherent analogue of monoidal DG-categories (an alternative approach would be to work with ∞ -categories – or to develop a theory of strong homotopy duoids, to be discussed later).

In this thesis, we work with non-symmetric operads either in the category of chain complexes (DG-operads) or in the category of topological/CW spaces (topological/CW operads).

Probably the most elementary 1-colored non-symmetric operad existing in the world is *Ass*, the operad of associative algebras with just one operation in each arity. However, being so small, *Ass* is not homotopically well-behaved (formally: not cofibrant in the model category of DG-operads). One can thus cofibrantly resolve *Ass* in various ways. The most standard resolution of *Ass* is A_∞ (whose topological version was introduced by Stasheff in [Sta], not yet in operadic terms). This resolution is given by cellular chains on certain CW-complexes (actually, polytopes) called *associahedra*. The idea is that instead of having an associative multiplication, we weaken the setup by having a generating operation in every arity, which altogether form a coherent system of corrections to non-associativity of the binary operation (for example, the differential of the ternary operation equals the associator of the binary one).

In the last fifty years, A_∞ -language has been profoundly developed by Keller [Kel2], Lefevre-Hasegawa [Lef], Lyubashenko [Lyu] and many others. One can speak of A_∞ -algebras, A_∞ -categories, A_∞ modules over A_∞ (or DG) algebras and categories, and so on. For morphisms between all of the above, one needs not only the operad A_∞ -but also an operadic bimodule M_∞ (also coming from a topological operadic bimodule of Stasheff *multiplihedra*).

Perhaps the main problem of A_∞ -language is with operadic diagonals. Recall the definition of a Hopf operad.

Definition. \mathcal{P} is a *Hopf operad* if it is equipped with a coassociative diagonal $\mathcal{P} \rightarrow \mathcal{P} \boxtimes \mathcal{P}$ consistent with operadic compositions.

Any topological operad is tautologically Hopf, because the monoidal structure on **Top** is Cartesian, and every topological space is equipped with a diagonal $X \rightarrow X \times X$. However, when topological spaces are additionally CW-complexes, these diagonals are never cellular except when $X = \text{pt}$.

For a Hopf operad, its category of algebras is monoidal. For example, Hopfness of the DG-operad *Ass* is the reason why for two DG-algebras A and B the complex $A \otimes B$ is naturally also a DG-algebra. One may ask a similar question about A_∞ -algebras:

Question. For two A and B two A_∞ -algebras, is there a natural A_∞ -structure on the complex $A \otimes B$?

An equivalent goal is to find an operadic diagonal for the DG-operad A_∞ . This question was answered in full generality by Sanedlidze-Umble

[SU]: the authors construct diagonals for cellular chains on permutahedra, and thus also for cellular chains on multiplihedra and associahedra that can be obtained from permutahedra by truncations. Similar diagonals can be constructed for other operads and operadic bimodules coming from topology via the functor of cellular chains. The problem with all these diagonals is that more often than not they are *not coassociative*. Thus the research on Hopfness of the DG-operad A_∞ and its relatives is not yet over.

Polyhedra

Polyhedra have been interesting for humanity since forever. In this thesis, we are interested in them mainly to the extent they play a role in providing explicit operadic resolutions. However, when seeing a family of operadically meaningful polytopes one cannot avoid the temptation to find a particularly nice embedding with integer coordinates.

The most classical family of operadically meaningful polytopes is *associahedra* of Tamari-Stasheff [Tam], [Sta]. They assemble into a topological version of A_∞ -operad. Their faces correspond to planar trees, and face inclusions correspond to edge contractions. In the original work of Stasheff, associahedra were defined as contractible CW-complexes, but they were later shown to be actual embedded polytopes via several embeddings, the most well-known due to Loday [Lod]. For the purpose of constructing diagonals, it is important that associahedra are directed polytopes via the Tamari order on their vertices. Note that this order is compatible with Loday's embedding (i.e. given by a functional, see [NTTV]).

Closely related to associahedra are multiplihedra which assemble into a topological operadic bimodule over the operad of associahedra. Their faces correspond to painted planar trees, their vertices carry a generalized Tamari order, and their polytopal embedding is due to Forcey [For].

New operadically meaningful polytopes continue appearing. Remarkable examples are the 2-associahedra of Bottman [Bot]. They form a relative 2-operad over associahedra [BC] and in topology give rise to the notion of $(A_\infty, 2)$ -algebras. Two warnings are due here. Firstly, the corresponding *finitely-dimensional* relative DG-2-operad is yet to be defined, since there is some non-cellularity intrinsic to the definition of a relative 2-operad in topological spaces. Secondly, 2-associahedra are yet defined only as contractible CW-complexes and as abstract polytopes, but not yet as embedded ones. The author, however, participates in a project with Spencer Backman and Nate Bottman dedicated to constructing such an embedding.

Questions addressed in this thesis

The first goal of this thesis was a certain computation in the model category of DG-categories. For an algebraic group G (or for its derived algebraic geometry analogue), Abad-Crainic introduced in [AC] the DG-category of its representations up to homotopy $\mathbf{hRep}(G)$.

Definition. A representation up to homotopy of G is an A_∞ -comodule over the Hopf algebra $\mathcal{O}(G)$ of functions on G . For V and W two such representations up to homotopy, the Hom complex $\mathbf{hRep}(G)^\bullet(V, W)$ is the usual A_∞ -Hom complex whose closed elements of degree 0 are A_∞ -morphisms.

Recall that usual representations of G are ordinary comodules over $\mathcal{O}(G)$. Thus, by generalities on A_∞ -(co)modules, the category $\mathbf{hRep}(G)$ DG-enhances the derived category $D(\mathbf{Rep}(G))$. Within $\mathbf{hRep}(G)$ we consider 1-dimensional complexes concentrated in degree 0 – this gives the subcategory $\mathbf{hChar}(G)$ of characters up to homotopy. In Chapter 2 of this thesis, we show that this category can be obtained as a homotopy limit of a certain cosimplicial system of DG-categories. The explicit formulas for taking such a homotopy limit were developed by [AØ] and [BHW], basing on the construction of simplicial resolutions that first appeared in [Hol], with proof details added in a paper that constitutes Chapter 1 of this thesis. Let A be $\mathcal{O}(G)$ viewed as a DG-category with one object.

Theorem. Let A^\bullet be the cosimplicial system dual to the BG -construction:

$$k \rightrightarrows A \rightrightarrows A^{\otimes 2} \quad \dots$$

Then $\mathbf{hChar}(G)$ is an explicit model for $\mathbf{holim}(A^\bullet)$ in $\mathbf{DGCat}(k)$.

The cosimplicial system above has the following property: since $\mathcal{O}(G)$ is a commutative algebra, all the DG-categories of A^\bullet are strictly monoidal. This brings us to the question:

Question. To what extent does this monoidality survive the passage to the homotopy limit?

A partial answer was obtained by Abad, Crainic and Dherin in [ACD], where a monoidal structure was constructed for the homotopy category of $\mathbf{hRep}(G)$, and thus for $\mathbf{hChar}(G)$ by restriction. This was done by identifying a DB (Differential Bar)-algebra Ω (secretly a 2-colored operad) controlling the objects of $\mathbf{hRep}(G)$, and a DB-bimodule \mathcal{T} over Ω (secretly a 2-colored operadic bimodule) controlling the morphisms. Then diagonals for Ω and \mathcal{T} were constructed, giving rise to tensor products of morphisms and objects in $\mathbf{hRep}(G)$. However, while the diagonal on Ω is coassociative, the diagonal on \mathcal{T} is not (only up to homotopy); neither is it compatible with the diagonal on Ω (again only up to homotopy). Thus the formulas of [ACD] do not give

an answer on the DG-level. It is interesting to find out a coherent structure (expectedly weaker than monoidal) that exists on DG-level and descends to the monoidal structure of [ACD].

To study structures on the DG-category $\mathbf{hRep}(G)$, we need a better understanding of its operadic nature. We develop this understanding in Chapter 3 of this thesis, where the notion of an operadic pair is introduced, and the operadic pair responsible for $\mathbf{hRep}(G)$ is identified, by translating [ACD] into operadic language.

To explain the idea behind operadic pairs, let us first consider the key example of the category of A_∞ -algebras. An A_∞ -algebra is an algebra over the DG-operad A_∞ . However, when talking about morphisms of A_∞ -algebras people normally mean A_∞ -morphisms, which are more general than the morphisms in the category of algebras over the operad A_∞ . To describe them conceptually, we also need M_∞ , an operadic bimodule over A_∞ that controls the morphisms, and a comultiplication on M_∞ that controls composition. Then the whole category of A_∞ -algebras with A_∞ -morphisms is described as the category of algebras over an operadic pair (A_∞, M_∞) (categories of algebras over operadic pairs are defined in this thesis).

To discuss $\mathbf{hRep}(G)$, we need a 2-colored operadic pair controlling DG-algebras and A_∞ -modules, with DG-morphisms on the algebra side and A_∞ -morphisms on the module side. As mentioned above, this operadic pair was already implicitly described in [ACD], albeit in DB-terms instead of operadic terms. Once this description is available, the questions about (weak) monoidality for $\mathbf{hRep}(G)$ are reformulated as questions about (weak) Hopf structures for the corresponding operadic pair.

All complexes figuring in the operads and bimodules above are best understood as coming from topology as cellular chains on certain polytopes. Recall that A_∞ is the operad of cellular chains on Stasheff associahedra ([Sta], [Tam]), and M_∞ is the bimodule of cellular chains on Stasheff multiplihedra ([For]). For the operadic pair behind $\mathbf{hRep}(G)$, the operad was implicitly shown in [ACD] to be cellular chains on cubes. Our key observation was spotting the family of polytopes behind the corresponding operadic bimodule. Surprisingly, these were freehedra of Saneblidze ([San]), which were defined to study loop spaces, and whose connection to the world of operads was not previously known. Identifying these polytopes allows us to relate tensor products of [ACD] to some well-known polyhedral diagonals (for cubes these are classical, for freehedra these are due to Saneblidze [San]). Sadly, spotting freehedra is not sufficient to answer the original question because the corresponding operadic pair fails to be Hopf on the nose - however, it has chances to be *weakly* Hopf. For this, we need to lift certain

known operadic diagonals to a bigger coherent structure.

Let us recall the machinery behind diagonals of Saneblidze-Umble (SU) type for cellular complexes of polytopes. The idea, omitting the signs, is rather transparent. Let P be a polytope whose edges within every face are a directed graph with one source, one sink and no cycles (so the vertices form a poset). Then for two faces F_1 and F_2 , one can write $F_1 \leq F_2$ if $\max F_1 \leq \min F_2$ (i.e. there exists a directed edge-path from $\max F_1$ to $\min F_2$). This (non-reflexive) relation on faces of P provides the following formula for a map $C_*(P) \rightarrow C_*(P)^{\otimes 2}$:

Formula.

$$\Delta : F \mapsto \sum_{\substack{F_1, F_2 \subset F \\ F_1 \leq F_2 \\ \dim F_1 + \dim F_2 = \dim F}} \pm F_1 \otimes F_2$$

Translating the formula into words: every face generator is sent to the sum of directed face chains within this face, with dimensions adding up to the dimension of the face. This formula *frequently* gives an output that is a cellular map: diagonals for simplices, cubes, freehedra, associahedra, multiplihedra and permutahedra are all instances of the formula above. Moreover, if the polytopes are assembled into an operad where operadic compositions respect directions, then straightforwardly such diagonals are consistent with operadic structure. The bad news is that such diagonals often fail to be coassociative (in particular this is the case for SU-diagonal on associahedra).

This brings us to two questions:

Question. Why does the formula work (i.e. produce a cellular map)?

Question. When the corresponding map is non-coassociative, can we obtain a coherent family of corrections compatible with operadic structure?

In our approach to these questions, we present, in Chapter 4 of this thesis, a surprising construction of a colored operad \mathcal{O}_P associated to a directed polytope. Colors of \mathcal{O}_P correspond to faces of P . The diagonal $\Delta =: \Delta_2^0$ is then realized as a component in the Poincare-Hilbert endomorphism of \mathcal{O}_P (which is a direct generalization of the notion of Poincare-Hilbert series into many colors). Other components are given by similarly looking formulas

$$\Delta_n^l : F \mapsto \sum_{\substack{F_i \subset F | i \in [1, n] \\ F_1 \leq \dots \leq F_n \\ \sum \dim F_i = \dim F + l}} \pm F_1 \otimes \dots \otimes F_n$$

Since the famous paper of Ginzburg-Kapranov [GK], it is known that for Koszul-dual symmetric Koszul operads their Poincare-Hilbert endomorphisms, after a certain modification of signs, are composition-inverse to each

other; thus for a Koszul self-dual Koszul operad its Poincaré-Hilbert endomorphism with modified signs is an involution. The modification of the theory for non-symmetric colored operads is due to van der Laan [vdL].

Assume we are working in characteristic 2 (merely to avoid signs). Let I be the Poincaré-Hilbert endomorphism for \mathcal{O}_P . We notice that the identity $I^2 = Id$ implies that operations Δ_n^0 assemble into an A_∞ -coalgebra structure on $C_*(P)$ (this answers both questions above). Note that there are more operations than those: the full structure is what we call *integrated A_∞ -coalgebra*. So let us formulate a conjecture.

Conjecture. For polytopes P satisfying a certain *shortness* condition, their operads \mathcal{O}_P are Koszul and Koszul self-dual, thus providing an integrated A_∞ -coalgebra structure on $C_*(P)$.

Using the toolkit of operadic Groebner bases by Dotsenko-Khoroshkin [DK] and Kharitonov-Khoroshkin [KK], we prove the conjecture in some particular cases.

Theorem. For simplices, polygons, and all products thereof, the conjecture holds.

Full generality remains a future goal. Also note that the shortness condition as formulated in this thesis fails for associahedra of dimension 4 and higher, so a modification of \mathcal{O}_P -construction has to be developed to work with non-short polytopes.

Let us now outline our approach to weak monoidality/Hopfness. Recall the *duoidal* categories of Batanin-Markl [BM].

Definition. A duoidal category C is a category with two monoidal products, \otimes and \boxtimes , and with functorial *interchanger* morphisms (not necessarily invertible):

$$(A \boxtimes B) \otimes (C \boxtimes D) \rightarrow (A \otimes C) \boxtimes (B \otimes D)$$

Similarly to how monoidal categories are home to monoids, duoidal categories are home to *duoids*.

Definition. A duoid in a duoidal category C is its object V equipped with associative operations $V \otimes V \rightarrow V$ and $V \boxtimes V \rightarrow V$, subject to a relation:

$$\begin{array}{ccccc} (V \boxtimes V) \otimes (V \boxtimes V) & \longrightarrow & (V \otimes V) \boxtimes (V \otimes V) & \longrightarrow & V \boxtimes V \\ \downarrow & & \downarrow & & \downarrow \\ V \otimes V & \longrightarrow & & \longrightarrow & V \end{array}$$

An important example of a duoidal category is $(\text{DG-})\text{Bimod}(A)$ for a Hopf algebra A , equipped with tensor products $\otimes = \otimes_A$ and $\boxtimes = \otimes_k$ (using the comultiplication). We now reinterpret monoidal DG-categories as duoids in $\text{DG-Bimod}(A)$ for a certain Hopf algebra A . Indeed, fix an object set $\text{Ob}(C)$, and consider the semisimple algebra

$$A = \bigoplus_{c \in \text{Ob}(C)} k \cdot 1_c$$

A DG-category C with object set $\text{Ob}(C)$ is a monoid in $\text{DG-Bimod}(A)$. Now suppose that we have the data of tensor product on objects $T : \text{Ob}(C) \times \text{Ob}(C) \rightarrow \text{Ob}(C)$. This makes A into a Hopf algebra. We observe that a monoidal DG-category C with object set $\text{Ob}(C)$ and object tensor product T is a duoid in $\text{DG-Bimod}(A)$. Thus the search for weak monoidality boils down to the questions:

Question. What are strong homotopy duoids?

Stasheff associahedra allow passing from monoids to strong homotopy monoids. Following the same logic, we aim to construct a family of polytopes to allow passing from duoids to strong homotopy duoids. These are *constrainahedra*, closely related to Bottman 2-associahedra [Bot]. In Chapter 5 of this thesis, we give their combinatorial definition, and realize them as embedded polytopes generalizing Loday’s embedding of associahedra [Lod] and Forcey’s embedding of multiplihedra [For]. We expect constrainahedra to carry a structure similar to that of a relative 2-operad of Bottman-Carmeli [BC]. Describing this structure is a goal of an ongoing project with Sergey Arkhipov, Spencer Backman and Nathaniel Bottman.

Structure of this thesis

This thesis consists of three papers, and two yet unpublished ongoing projects in which several results have been proved.

The first paper is “A note on a Holstein construction” (coauthored with Sergey Arkhipov, published in HHA), with the following abstract:

We clarify details and fill certain gaps in the construction of a canonical Reedy fibrant resolution for a constant simplicial DG-category due to Holstein.

The second paper is “Homotopy characters as a homotopy limits” (coauthored with Sergey Arkhipov, under revision for HHA), with the following abstract:

For a Hopf DG-algebra corresponding to a derived algebraic group, we compute the homotopy limit of the associated cosimplicial system of DG-algebras given by the classifying space construction. The homotopy limit is taken in the model category of DG-categories. The objects of the resulting DG-category are Maurer-Cartan elements of $\text{Cobar}(A)$, or 1-dimensional A_∞ -comodules over A . These can be viewed as characters up to homotopy of the corresponding derived group. Their tensor product is interpreted in terms of Kadeishvili's multibraces. We also study the coderived category of DG-modules over this DG-category.

The third paper is "Cellular chains on freehedra and operadic pairs", with the following abstract:

The paper is devoted to explaining the operadic meaning of freehedra, a family of polytopes originally defined to study free loop spaces. We introduce the notion of operadic pairs and algebras over them. Cellular chains on Stasheff associahedra and Stasheff multiplihedra assemble into a two-colored operadic pair that governs A_∞ -algebras and A_∞ -modules over them, with maps that are A_∞ in both colors. An important quotient of this operadic pair is given by cellular chains on cubes and freehedra.

The first unpublished project is "Colored operads from directed polytopes", where a construction of a colored operad associated to a directed polytope is given, and Koszul self-duality of such operads is proven in several cases.

The second unpublished project is "Constrainahedra", where a family of polytopes generalizing associahedra and multiplihedra is constructed, and an embedding generalizing Loday's and Forcey's embeddings is proved.

Acknowledgements

I am grateful to my advisor Lars Hesselholt and my co-advisor Ryszard Nest for their support and endless patience towards my imperfect mathematical tastes. I am grateful to my collaborator Sergey Arkhipov for sharing some of those tastes.

I am grateful to Jim Stasheff for encouragement, for his interest in my work and for introducing me to concepts and people.

I am grateful to my undergraduate advisors Misha Verbitski, Alexander Kuznetsov, Sergey Loktev and Christopher Brav for supporting me at earlier stages of my long and winding mathematical road.

I am grateful to Sveta Makarova for her friendship, trust, and for saving me from many failures along the way.

I am grateful to my school teacher Yakov Abramson who sparked my interest in mathematics, to Anton Fetisov who persuaded me that mathematics can become my path in life, and to Lev Soukhanov and Alexander Efimov who taught me informally.

I am grateful to Spencer Backman and Nate Bottman who collaborate with me.

Bibliography

- [AC] C.A. Abad, M. Crainic. “Representations up to homotopy and Bott’s spectral sequence for Lie groupoids”. *Advances in Mathematics*, 248, 416–452 (2013).
- [ACD] C.A. Abad, M. Crainic, B. Dherin. “Tensor products of representations up to homotopy”. *Journal of Homotopy and Related Structures*, 6(2), 239–288 (2011).
- [AØ] S. Arkhipov, S. Ørsted. “Homotopy limits in the category of dg-categories in terms A_∞ comodules”. ArXiv preprint 1812.03583, (2018).
- [BM] M. Batanin, M. Markl, “Centers and homotopy centers in enriched monoidal categories”. *Advances in Mathematics* 230 , 4-6, 1811–1858, (2012).
- [BHW] J. Block, J. V. Holstein, and Z. Wei. “Explicit homotopy limits of dg categories and twisted complexes”. *Homology, Homotopy and Applications* 19(2), (2017), pp. 343–371.
- [BV] J. M. Boardman, R.M. Vogt. “Homotopy Invariant Algebraic Structures on Topological Spaces”. *Lecture Notes in Mathematics*, 347, (1973).
- [BK] A. Bondal, M.M. Kapranov. “Enhanced triangulated categories”. *Mathematics of the USSR-Sbornik* 70:1, 93–107, (1991).
- [Bot] N. Bottman. “2-associahedra”. *Algebraic and Geometric Topology*, (2019).
- [BC] N. Bottman, S. Carmelli. “ $(A_\infty - 2)$ -categories and relative 2-operads”. *Higher Structures* (2021).
- [DK] V. Dotsenko, A. Khoroshkin, “Gröbner bases for operads”. *Duke Math. J.* 153 (2) 363 - 396, (2010).
- [Fao1] G. Faonte. “Simplicial nerve of an A-infinity category”. *Theory and Applications of Categories*, Vol. 32, 2017, No. 2, pp 31-52.

- [Fao2] G. Faonte. “A-infinity functors and homotopy theory of dg-categories”. *Journal of Noncommutative Geometry*, (2017).
- [For] S. Forcey. “Convex Hull Realizations of the Multiplihedra”. *Topology and its Applications*, 56(2), 326-347 (2008).
- [GK] V. Ginzburg, M. Kapranov. “Koszul duality for operads”. *Duke* (1994).
- [Hol] J. Holstein. “Properness and simplicial resolutions for the model category dgCat ”. *Homology Homotopy Appl.*, 16(2):263–273, (2014).
- [Hov] M. Hovey. “Model categories”. Volume 63 of *Mathematical Surveys and Monographs*. American Mathematical Society, Providence, RI, (1999).
- [Hir] Ph. S. Hirschhorn. “Model Categories and Their Localizations”. *AMS Mathematical Surveys and Monographs*, Vol. 99, (2003).
- [Kel1] B. Keller, “Deriving DG categories”, *Ann. Sci. Ecole Norm. Sup.* 27 (1995), 63–102.
- [Kel2] B. Keller. “A-infinity algebras, modules and functor categories”. *HHA*
- [KK] V. Kharitonov, K. Khoroshkin. “Gröbner Bases for Coloured Operads”. *Annali di Matematica Pura ed Applicata* (2021).
- [Lef] K. Lefevre-Hasegawa. “Sur les A-infini catégories”
- [Lod] J.-L. Loday. “Realization of the Stasheff polytope”, *Archiv der Mathematik*, 83, 267–278 (2004)
- [LO] V. Lunts, D. Orlov, “Uniqueness of enhancements for triangulated categories”, *J. Amer. Math. Soc.* 23 (2010), 853–908.
- [LS] V. Lunts, O.M. Schnürer, “New enhancements of derived categories of coherent sheaves and applications”, *J. Algebra* 446 (2016), 203–274.
- [Lur] J. Lurie. “Higher Algebra”.
- [Lyu] V. Lyubashenko. “Category of A-infinity-categories”.
- [May] May, J. P. (1972). “The Geometry of Iterated Loop Spaces”. *Lecture Notes in Mathematics*. 271.
- [NTTV] Naruki Masuda, Hugh Thomas, Andy Tonks, Bruno Vallette. “The diagonal of the associahedra”.

- [San] S. Sanedlidze. “The bitwisted Cartesian model for the free loop fibration”. *Topology and its Applications*, 156(5), 897-910 (2009).
- [SU] S. Sanedlidze, R. Umble. “Diagonals on the permutahedra, multiplihedra and associahedra”. *Homology, Homotopy and Applications*, 6(1), 363–411 (2004).
- [Sta] J. Stasheff. “Homotopy associativity of H-spaces. I, II”. *Transactions of the American Mathematical Society*, 108, 293–312 (1963).
- [Tab] G. Tabuada. “Une structure de categorie de modeles de Quillen sur la categorie des dg-categories”. *C. R. Acad. Sci. Paris. I* 340, (2004).
- [Tam] D. Tamari. “Monoïdes préordonnés et chaînes de Malcev”, Thèse, Université de Paris, MR 0051833 (1951).
- [Tam1] D. Tamarkin. “What do DG-categories form?”. *Compositio Mathematica* 143(7), (2007).
- [Toe] B. Toen. “The homotopy theory of dg-categories and derived Morita theory”
- [vdL] P. van der Laan. “Coloured Koszul duality and strongly homotopy operads”. *Arxiv* (2004).

Part II
Papers

Chapter 1

A note on a Holstein construction

1.1 Introduction

The present paper (co-authored with Sergey Arkhipov) grew out of attempts to understand technical details of a proof in [Hol]. Thus, from the very start, we do not claim that our work contains original insights.

We begin by describing our interest. In the papers [BHW], [AØ] homotopy gluing of DG-categories was studied.

The standard example is given by Abelian categories of sheaves on open sets for a Čech covering of a topological space. One seeks a lift for gluing of Abelian categories to DG-level. Unlike with ordinary categories, one requires coherence data on multiple intersections in the covering to be given by weak equivalences, not by isomorphisms. The answer is spelled out naturally in the language of homotopy limits for cosimplicial diagrams of DG-categories. In [AØ] Sebastian Ørsted and the first author provided an explicit model for such a homotopy limit.

The construction relies on an explicit model for *powering* by simplicial sets in the model category of DG-categories due to Holstein (see [Hol], Proposition 3.6). The key ingredient in the latter is a canonical simplicial resolution of a DG-category introduced in the same paper (see [Hol], Propositions 3.9 and 3.10). Our goal in the present paper is to add details to the sketch of the proofs of those statements in Holstein's work.

The author's strategy in that paper was to generalize a proof of Tabuada that a certain explicit DG-category provides a *path object* construction (see [Tab2], Proposition 3.3). However, the original proof of Tabuada had some

details omitted, which led to a flaw in Holstein’s approach. We fill the gap, and this, together with certain explicit calculations, is the main content of the present note.

Let us outline the structure of the paper. In the second section we recall the construction of Dwyer-Kan model structure on the category of DG-categories. Then, following Lefèvre-Hasegawa [Lef] and Faonte [Fao], we discuss close relatives of DG-functors called A_∞ -functors. We describe the category of A_∞ -functors between two DG-categories playing the role of internal Hom in the category of DG-categories. We conclude the section by recalling the Reedy model structure on a diagram category with values in a model category. In particular this includes our main object of interest – the category of simplicial DG-categories.

In the third section we provide a detailed proof of Holstein’s theorem filling the gap in his original approach. In particular, the proof of fibrancy of matching maps is given by explicit lifts.

Our proof is based on direct calculations of lifts and on the use of an elegant description for homotopy equivalences of A_∞ -functors suggested to us by Efimov. In the appendix, we provide an alternative approach to the proof developing the ideas of Tabuada and Holstein. The main strategy there is to reduce the statement to the case of pretriangulated DG-categories via the construction of pretriangulated envelope.

Acknowledgements. The gaps in the last part of the paper [Hol] were noticed by several people, in particular, by Boris Shoikhet. We thank him for sharing his concerns at an early stage of the present work. We also thank Julian Holstein for stimulating discussions.

The idea to study pointwise homotopy equivalences of A -infinity functors is due to Alexander Efimov, the context and the exact reference were kindly provided by Sebastian Ørsted. This improvement clarified and simplified the exposition greatly, thus the final form of the paper owes a lot to Efimov and Ørsted. We thank Edouard Balzin for careful proofreading of the text, and Timothy Logvinenko for useful comments.

The first author was partially supported by QGM. The second author was partially supported by Laboratory of Mirror Symmetry NRU HSE, RF Government grant, ag. N 14.641.31.0001. The second author was also supported by the Danish National Research Foundation through the Centre for Symmetry and Deformation (DNRF92).

1.2 Homotopy theory of DG-categories

Below we collect a few constructions and statements to be used in the next section and necessary to formulate the theorem of Holstein. We work over a base field k . Recall that a DG-category is a category enriched over the monoidal category $\mathbf{Com}(k\text{-Mod})$. The homotopy category for a DG-category \mathcal{A} is denoted by $H^0(\mathcal{A})$. We denote the category of small DG-categories and DG-functors by $\mathbf{DGCat}(k)$.

1.2.1 Dwyer-Kan model structure for DG-categories

Recall that a DG-functor is called a quasiequivalence if it induces quasi-isomorphisms on all Hom complexes and becomes an equivalence of the homotopy categories. Quasiequivalences are a part of *Dwyer-Kan* model structure on $\mathbf{DGCat}(k)$ constructed in [Tab]. Recall the description of the three standard classes of morphisms.

We say that a DG-functor $F: \mathcal{A} \rightarrow \mathcal{D}$ is

- a weak equivalence, if it is a quasiequivalence
- a fibration, if it is surjective on all Hom complexes and is an isofibration at the level of H^0 , i.e. for a homotopy equivalence $F(x) \xrightarrow{u} y$ in \mathcal{D} there exists a homotopy equivalence $x \xrightarrow{u'} y'$ such that $F(u') = u$:

$$\begin{array}{ccc}
 \mathcal{A} & & x \xrightarrow{u'} y' \\
 \downarrow F & & \downarrow \\
 \mathcal{D} & & F(x) \xrightarrow{u} y
 \end{array}$$

- a cofibration, if it admits the left lifting property with respect to all trivial fibrations.

Theorem 1.2.1. [Tab] The category $\mathbf{DGCat}(k)$ is equipped with cofibrantly generated model structure with weak equivalences, fibrations and cofibrations defined as above.

1.2.2 A_∞ functors as inner Hom

In $\mathbf{DGCat}(k)$, one can take the naive tensor product $\mathcal{A} \otimes \mathcal{D}$ and the naive inner Hom $\mathbf{DGFun}(\mathcal{A}, \mathcal{D})$ which make $\mathbf{DGCat}(k)$ into a closed monoidal category. However, these notions are not consistent with the model structure discussed above, and thus do not make $\mathbf{HoDGCat}(k)$ into a closed monoidal category. This can be amended by considering derived versions, \otimes^L and \mathbf{RHom} (see [Toë]), which are defined up to quasiequivalence but which make

$H\text{odGCat}(\mathbf{k})$ into a closed monoidal category.

Of existing models for RHom , we make use of the one given by the DG-category of A_∞ -functors.

Definition 1.2.2. For two DG-categories \mathbf{A}, \mathbf{B} , a strictly unital A_∞ functor $F: \mathbf{A} \rightarrow \mathbf{B}$ consists of the following data:

- $F_0: \text{Ob}\mathbf{A} \rightarrow \text{Ob}\mathbf{B}$
- for all $n \geq 1$ and $x_0, \dots, x_n \in \text{Ob}\mathbf{A}$,

$$F_n: \mathbf{A}(x_{n-1}, x_n) \otimes \dots \otimes \mathbf{A}(x_0, x_1) \rightarrow \mathbf{B}(F_0(x_0), F_0(x_n))$$

of degree $1 - n$, subject to

$$\begin{aligned} & \sum_{s=0}^{n-2} (-1)^{n-s} F_{n-1}(Id^{\otimes s} \otimes m \otimes Id^{\otimes(n-s-2)}) \\ & + \sum_{s=0}^{n-1} (-1)^{n-1} F_n(Id^{\otimes s} \otimes d \otimes Id^{\otimes(n-s-1)}) \\ & = dF_n + \sum_{s=1}^{n-1} (-1)^{ns} m(F_s \otimes F_{n-s}), \end{aligned}$$

where d is the differential and m is the composition.

Definition 1.2.3. For two DG-categories \mathbf{A}, \mathbf{B} , the DG-category $A_\infty \text{Fun}(\mathbf{A}, \mathbf{B})$ has strictly unital A_∞ functors as objects. For F, G being such, the complex $A_\infty \text{Fun}(\mathbf{A}, \mathbf{B})(F, G)$ is, in degree l ,

$$\prod_{\substack{n \geq 0 \\ x_0, \dots, x_n \in \text{Ob}(\mathbf{A})}} \text{Hom}(\mathbf{A}(x_{n-1}, x_n) \otimes \dots \otimes \mathbf{A}(x_0, x_1), \mathbf{B}(F_0(x_0), G_0(x_n))[l - n])$$

For $a \in A_\infty \text{Fun}^l(\mathbf{A}, \mathbf{B})(F, G)$, its differential $d_{A_\infty}(a)$ has its component at (x_0, \dots, x_n) equal to

$$\begin{aligned} & \pm d(a_{x_0, \dots, x_n}) + \sum_{i=1}^n \pm m(a_{x_i, \dots, x_n} \otimes F_{x_0, \dots, x_n}) \\ & + \sum_{i=0}^{n-1} \pm m(G_{x_i, \dots, x_n} \otimes a_{x_0, \dots, x_i}) \\ & + \sum_{i=0}^{n-1} \pm a_{x_0, \dots, x_n} (Id^{\otimes i} \otimes d \otimes Id^{\otimes(n-i-1)}) \\ & + \sum_{i=0}^{n-2} \pm a_{x_0, \dots, \hat{x}_i, \dots, x_n} (Id^{\otimes i} \otimes m \otimes Id^{\otimes(n-i-2)}) \end{aligned}$$

The definitions above are a special case of the general theory of A_∞ categories and their morphisms. The discussion in full generality and including sign conventions can be found e.g. in [Lef].

In [Fao], the following theorem is proved.

Theorem 1.2.4. The DG-category $A_\infty \text{Fun}(\mathcal{A}, \mathcal{B})$ is a model for $\text{RHom}(\mathcal{A}, \mathcal{B})$.

1.2.3 Reedy model structure for diagrams

To talk about (co)simplicial DG-categories, we need the following technique (see [Hir] or [Hov]).

Definition 1.2.5. A Reedy category is a category \mathcal{I} together with a degree function $d: \text{Ob}(\mathcal{I}) \rightarrow \lambda$ (where λ is an ordinal, typically \mathbb{N}) and with two full subcategories \mathcal{I}^+ and \mathcal{I}^- , subject to the following conditions:

- every non-identity map in \mathcal{I}^+ increases the degree;
- every non-identity map in \mathcal{I}^- decreases the degree;
- every map f in \mathcal{I} admits a unique factorization $f = f^+ \circ f^-$, where $f^- \in \mathcal{I}^-$ and $f^+ \in \mathcal{I}^+$.

The *simplicial category* Δ of finite ordinals and order preserving maps is an example of a Reedy category – in its case, $d([n]) = n$, the subcategory Δ^+ consists of injections and the subcategory Δ^- consists of surjections. Also, for \mathcal{I} a Reedy category, \mathcal{I}^{op} is also a Reedy category with the same degree function, with $(\mathcal{I}^{\text{op}})^+ = (\mathcal{I}^-)^{\text{op}}$ and with $(\mathcal{I}^{\text{op}})^- = (\mathcal{I}^+)^{\text{op}}$.

For a Reedy category \mathcal{I} and an arbitrary model category \mathcal{M} , the diagram category $\mathcal{M}^{\mathcal{I}}$ is equipped with Reedy model structure. We need the following definitions to describe it.

- Definition 1.2.6.**
1. For $i \in \mathcal{I}$, the latching category $\delta(I^+ \downarrow i)$ is a full subcategory of the overcategory $(\mathcal{I}^+ \downarrow i)$ consisting of all arrows except for id_i .
 2. For $i \in \mathcal{I}$ and $D \in \mathcal{M}^{\mathcal{I}}$, the corresponding latching object is

$$L_i D = \text{colim}_{j \rightarrow i \in \delta(I^+ \downarrow i)} D(j).$$

3. Dually, for $i \in \mathcal{I}$, the matching category $\delta(i \downarrow \mathcal{I}^-)$ is a full subcategory of the undercategory $(i \downarrow \mathcal{I}^-)$ consisting of all arrows except for id_i .

4. For $i \in \mathcal{I}$ and $D \in \mathcal{M}^{\mathcal{I}}$, the corresponding matching object is

$$M_i D = \lim_{i \rightarrow j \in \delta(i) \downarrow \mathcal{I}^-} D(j).$$

Note that there are natural maps $L_i D \xrightarrow{l_i D} D(i) \xrightarrow{m_i D} M_i D$, and, for a map of diagrams $f: D \rightarrow D'$, maps $L_i(f): L_i D \rightarrow L_i D'$ and $M_i(f): M_i D \rightarrow M_i D'$. Let us say that a map of diagrams $f: D \rightarrow D'$ is

- a Reedy weak equivalence, if $\forall i \in \mathcal{I}$ the map $f_i: D(i) \rightarrow D'(i)$ is a weak equivalence in \mathcal{M}
- a Reedy cofibration, if $\forall i \in \mathcal{I}$, the arrow

$$l_i f: L_i(D') \prod_{L_i D} D(i) \rightarrow D'(i)$$

is a cofibration in \mathcal{M} :

$$\begin{array}{ccc} L_i(D) & \xrightarrow{L_i(f)} & L_i(D') \\ l_i D \downarrow & & \downarrow \\ D(i) & \xrightarrow{\quad} & L_i(D') \prod_{L_i D} D(i) \\ & \searrow f_i & \downarrow l_i f \\ & & D'(i) \end{array}$$

- a Reedy fibration, if $\forall i \in \mathcal{I}$ the arrow

$$m_i f: D(i) \rightarrow M_i(D) \times_{M_i(D')} D'(i)$$

is a fibration in \mathcal{M} :

$$\begin{array}{ccc} D(i) & \xrightarrow{f_i} & D'(i) \\ m_i f \dashrightarrow & & \downarrow m_i D' \\ M_i(D) \times_{M_i(D')} D'(i) & \xrightarrow{\quad} & D'(i) \\ m_i D \searrow & & \downarrow m_i D' \\ M_i(D) & \xrightarrow{M_i(f)} & M_i(D') \end{array}$$

Theorem 1.2.7. The three classes of morphisms define a model structure on the category $\mathcal{M}^{\mathcal{I}}$.

One notices that for $0 \rightarrow D$ the Reedy cofibrancy condition boils down to the cofibrancy of $L_i(D) \rightarrow D(i)$ for every i , and, dually, for $D \rightarrow 1$ the Reedy fibrancy condition boils down to the fibrancy of $D(i) \rightarrow M_i(D)$ for every i . Thus a diagram is Reedy cofibrant if all its latching maps are cofibrations, and a diagram is Reedy fibrant if all its matching maps are fibrations.

In this note, our source category is Δ^{op} , and our target category is $\text{DGCat}(k)$ with Dwyer-Kan model structure.

1.3 Reedy fibrant replacement for simplicial DG-categories

1.3.1 Holstein construction

Denote the DG-category obtained by the k -linearization of the category for the totally ordered set $\{0, \dots, n\}$ by $k[n]$.

For a DG-category \mathbf{A} , the DG-category $A_\infty \text{Fun}^\circ(k[n], \mathbf{A})$ has A_∞ functors $k[n] \rightarrow \mathbf{A}$ sending arrows to homotopy equivalences as objects and the complexes of A_∞ natural transformations as morphisms. We spell out the formulas for our case. An object $(X, f) \in A_\infty \text{Fun}^\circ(k[n], \mathbf{A})$ is the data of $(n + 1)$ objects X_0, \dots, X_n in \mathbf{A} and the morphisms $\{f_I\}$ where I runs over all subsets of $\{0, \dots, n\}$ of cardinalities at least 2, with $f_{i_0, i_1, \dots, i_k} \in \mathbf{A}^{1-k}(X_{i_0}, X_{i_k})$, subject to the following conditions:

- $d(f_{i_0, \dots, i_k}) = \sum_{s=1}^{k-1} (-1)^s f_{i_0, \dots, \widehat{i_s}, \dots, i_k} - \sum_{s=1}^{k-1} (-1)^s f_{i_s, \dots, i_k} \circ f_{i_0, \dots, i_s}$
- all $f_{i,j}$ are homotopy equivalences.

Following Holstein, we use the following notation:

- $d(\phi)_{i_0, \dots, i_k} = d(\phi_{i_0, \dots, i_k})$
- $(\Delta\phi)_{i_0, \dots, i_k} = (-1)^{|\phi|} \sum_{s=1}^{k-1} (-1)^s \phi_{i_0, \dots, \widehat{i_s}, \dots, i_k}$
- $(\phi \circ \psi)_{i_0, \dots, i_k} = \sum_{s=0}^k (-1)^{|\phi|s} \phi_{i_s, \dots, i_k} \circ \psi_{i_0, \dots, i_s}$, where one should read 0 if indexing subset is impossible.

In this notation, upon fixing $|f| = 1$, the first of the conditions above becomes Maurer-Cartan equation:

$$d(f) + \Delta f + f \circ f = 0.$$

The Hom complexes in $A_\infty \text{Fun}^\circ(k[\bullet], \mathbf{A})$ are the complexes of A_∞ natural transformations, namely

$$A_\infty \text{Fun}^\circ(k[\bullet], \mathbf{A})((X, f), (Y, g)) = \bigoplus_{\{i_0, \dots, i_k\} \subset \{0, \dots, n\}} A(X_{i_0}, Y_{i_k})[-k]$$

with differential

$$d_{A_\infty}(a) = d(a) + \Delta a + a \circ f - (-1)^{|a|} g \circ a.$$

Explicitly, a degree m morphism $a: (X, f) \rightarrow (Y, g)$ consists of components $\{a_I\}$ where I runs over all non-empty subsets of $\{0, \dots, n\}$, with $a_{i_1, \dots, i_k} \in A^{1-k}(X_{i_1}, Y_{i_k})$.

As $k[\bullet]$ is a cosimplicial DG-category, $A_\infty \text{Fun}^\circ(k[\bullet], \mathbf{A})$ becomes a simplicial DG-category, with structure maps obtained by precompositions with structure maps of $k[\bullet]$.

One of the main results in the paper [Hol] is the following theorem (see Propositions 3.9 and 3.10 in that paper).

Theorem 1.3.1. The simplicial DG-category $A_\infty \text{Fun}^\circ(k[\bullet], \mathbf{A})$ as an object of $\text{DGCat}(k)^{\Delta^{\text{op}}}$ is a Reedy fibrant replacement of $c\mathbf{A}$, the constant simplicial DG-category for a DG-category \mathbf{A} , with respect to Dwyer-Kan model structure on the target model category $\text{DGCat}(k)$.

For convenience, we denote $A_\infty \text{Fun}^\circ(k[\bullet], \mathbf{A}) =: F_\bullet(\mathbf{A})$.

The proof naturally consists of two parts. Firstly, one has to show that for every n , the natural (constant functor) inclusion $\mathbf{A} \rightarrow F_n(\mathbf{A})$ is a quasiequivalence. Secondly, one has to show that $F_\bullet(\mathbf{A})$ is Reedy fibrant.

1.3.2 Quasiequivalences

In both parts of the proof, we rely on the following general fact from the homotopy theory of A_∞ -functors, due to Lefèvre-Hasegawa, Proposition 8.2.2.3 in [Lef]. We reduce the generality by considering DG-categories instead of A_∞ -categories.

Lemma 1.3.2. Let \mathcal{A}, \mathcal{B} be two DG-categories, F, G two A_∞ -functors $\mathcal{A} \rightarrow \mathcal{B}$ and $a: F \rightarrow G$ a closed A_∞ natural transformation of degree 0. Then a is a homotopy equivalence in $A_\infty \text{Fun}(\mathcal{A}, \mathcal{B})$ if and only if for every $X \in \mathcal{A}$ the component $a_X: F(X) \rightarrow G(X)$ is a homotopy equivalence in \mathcal{B} .

Note if the DG-category $A_\infty \text{Fun}(\mathcal{A}, \mathcal{B})$ is replaced by the “naive version of inner Hom” $\text{DGFun}(\mathcal{A}, \mathcal{B})$, then the statement of the lemma above would

not hold.

We can now prove the following theorem.

Theorem 1.3.3. For every n , the constant functor inclusion $c: \mathbf{A} \rightarrow F_n(\mathbf{A})$ is a quasiequivalence.

Proof. We first check that c induces quasiisomorphism on all Hom complexes. It is injective on cohomology – if for $f: X \rightarrow Y$ we have $cf = d_{A_\infty}(g)$, then in particular $f = (cf)_0 = d(g_0)$. To show that c is surjective on cohomology, let a be a closed map $cX \rightarrow cY$ for $X, Y \in \mathbf{A}$. Let us check that a is in the same cohomology class as $c(a_0)$, i.e. that $a - c(a_0)$ is exact. The fact that $d_{A_\infty}(a) = 0$ corresponds to the following formulas:

$$\begin{cases} d(a_i) = 0 \\ d(a_{i_0 \dots i_k}) = a_{i_1 \dots i_k} - a_{i_0 \dots i_{k-1}} + \sum_{s=1}^{k-1} (-1)^s a_{i_0 \dots \widehat{i_s} \dots i_k} \end{cases}$$

Then $a - c(a_0) = d(b)$, where

$$b_{i_0 \dots i_k} = \begin{cases} 0 & i_0 = 0 \\ a_{0i_0 \dots i_k} & i_0 \neq 0 \end{cases}$$

We then check that c is essentially fully faithful at the level of H^0 , namely that any object $(X, f) \in F_n(\mathbf{A})$ is homotopy equivalent to an object in the image of c . Indeed, consider the object cX_0 . The A_∞ -natural transformation $a: cX_0 \rightarrow (X, f)$ is given by

$$a_i = \begin{cases} 1_{X_0} & i = 0 \\ f_{0i} & \text{otherwise} \end{cases}$$

$$a_{i_0 \dots i_k} = \begin{cases} 0 & i_0 = 0 \\ f_{0i_0 \dots i_k} & \text{otherwise} \end{cases}$$

The fact that $d_{A_\infty}(a) = 0$ follows from Maurer-Cartan condition for f .

Note that 1_{X_0} and f_{0i} are all homotopy equivalences in \mathbf{A} . Then, by Lemma 1.3.2, a is a homotopy equivalence. \square

Remark 1.3.4. In [Hol], it was first shown that every $(X, f) \in F_n(\mathbf{A})$ can be strictified, i.e. it is homotopy equivalent to an (\tilde{X}, \tilde{f}) where all compositions are strict and $\tilde{f}_{i_0 \dots i_k} = 0$ for $k > 1$. However, Lemma 1.3.2 does not become elementary even in this generality, and once we have this lemma, strictification becomes unnecessary.

1.3.3 Reedy fibrancy

We now prove Reedy fibrancy of $F_\bullet(\mathbf{A})$ by showing that the matching maps are Dwyer-Kan fibrations – namely, that they are surjective on all the Hom complexes and that they are isofibrations at the level of H^0 . We begin from explicitly describing these matching maps.

By definition of a matching object, we have

$$M_n F(\mathbf{A}) = \lim_{\delta([n] \downarrow (\Delta^{\text{op}})_-)} F_\bullet(\mathbf{A}) = \lim_{[m] \hookrightarrow [n]} F_m(\mathbf{A}).$$

This is the data of A_∞ functors without the highest homotopies. Namely, an object $(X, f) \in M_n F(\mathbf{A})$ is the data of $(n + 1)$ objects X_0, \dots, X_n in \mathbf{A} and the morphisms $\{f_I\}$ where I runs over all subsets of $\{0, \dots, n\}$ of cardinalities from 2 to n (that is, the subset $\{0, \dots, n\}$ is not included) with $f_{i_0, i_1, \dots, i_k} \in A^{1-k}(X_{i_0}, X_{i_k})$, satisfying the following conditions:

- $d(f) + \Delta f + f \circ f = 0$;
- all $f_{i,j}$ are homotopy equivalences.

Similarly, the morphisms are given by complexes of A_∞ natural transformations without highest homotopies. Namely, a degree m morphism $a: (X, f) \rightarrow (Y, g)$ is the set of morphisms $\{a_I\}$ where I runs over all non-empty subsets of $\{0, \dots, n\}$ except for $\{0, \dots, n\}$ itself, with $a_{i_1, \dots, i_k} \in A^{1-k}(X_{i_1}, Y_{i_k})$, and with differential given by

$$d_{A_\infty}(a) = d(a) + \Delta a + a \circ f - (-1)^{|a|} g \circ a.$$

The matching map $m_n: F_n(\mathbf{A}) \rightarrow M_n F(\mathbf{A})$ is the natural forgetful functor that, on objects, forgets $f_{0,1,\dots,n}$, and, on morphisms, forgets $a_{0,1,\dots,n}$ (this will be called truncation). We write $(X, f) \mapsto (X, f_{\leq n})$.

The first part of Reedy fibrancy for $F_\bullet(\mathbf{A})$ is the following elementary proposition.

Proposition 1.3.5. The forgetful functor m_n is surjective on Hom complexes.

Proof. A preimage of a truncated A_∞ transformation a between $(X, f_{\leq n})$ and $(Y, g_{\leq n})$ can be obtained by simply assigning any value (e.g. 0) to $a_{0,1,\dots,n}$, as there are no conditions on the components. \square

Showing that m_n is a homotopy isofibration requires more work. In our computations, we use the following lemma, from [Kon], Section 5, Theorem 1 (see also [Sho], Lemma 3.6).

Lemma 1.3.6. For any DG-category \mathbf{A} and a homotopy equivalence $f \in \mathbf{A}^0(X, Y)$ it is always possible to find $f \in \mathbf{A}^0(Y, X)$, $r_X \in \mathbf{A}^{-1}(X, X)$, $r_Y \in \mathbf{A}^{-1}(Y, Y)$ and $r_{XY} \in \mathbf{A}^{-2}(X, Y)$ such that:

- $gf = 1_X + d(r_X)$
- $fg = 1_Y + d(r_Y)$
- $fr_X - r_Yf = d(r_{XY})$

Now suppose that we have an object $(Y, g) \in M_n F(\mathbf{A})$ and a homotopy equivalence $a: (X, f_{\leq n}) \rightarrow (Y, g)$ (with homotopy inverse \bar{a}). To show that m_n is an isofibration on H^0 , we need to lift a to a homotopy equivalence in $F_n(\mathbf{A})$.

Remark 1.3.7. In [Hol], the lift of the object is constructed – namely, $g_{0, \dots, n}$ is given with $d(g_{0, \dots, n}) = (\Delta g + g \circ g)_{0, \dots, n}$. We insignificantly modify the lift and provide the computation for the sake of reader's convenience. In what follows, let $\alpha \circ' \beta$ denote $\alpha \circ \beta$ without the term $\alpha_{0, \dots, n} \circ \beta_0$. Let r_{Y_0} be such that $a_0 \bar{a}_0 = 1_{Y_0} + d(r_{Y_0})$. The indexing subset is always $\{0, 1, \dots, n\}$ and is omitted.

Proposition 1.3.8. Setting

$$g_{0, \dots, n}: = (\Delta a + a \circ f - g \circ' a) \bar{a}_0 - (\Delta g + g \circ g) r_{Y_0}$$

indeed gives $d(g_{0, \dots, n}) = \Delta g + g \circ g$, thus this lifts the object.

Proof. One first checks that $d(\Delta g + g \circ g) = 0$. Then

$$d((\Delta g + g \circ g) r_{Y_0}) = (\Delta g + g \circ g) d(r_{Y_0}) = (\Delta g + g \circ g) (a_0 \bar{a}_0 - 1).$$

So we are left to see that

$$d(\Delta a + a \circ f - g \circ' a) \bar{a}_0' = (\Delta g + g \circ g) a_0 \bar{a}_0$$

– or that

$$d(\Delta a + a \circ f - g \circ' a) = (\Delta g + g \circ g) a_0,$$

which is an explicit computation. \square

We now construct the *closed* lift of the morphism a – namely, we give a formula for $a_{0, \dots, n}$ with $d(a_{0, \dots, n}) = (\Delta a + a \circ f - g \circ a)_{0, \dots, n}$. Let r_{X_0} be such that $\bar{a}_0 a_0 = 1_{X_0} + d(r_{X_0})$, let r_{Y_0} be such that $a_0 \bar{a}_0 = 1_{Y_0} + d(r_{Y_0})$, and let $r_{X_0 Y_0}$ be such that $a_0 r_{X_0} - r_{Y_0} a_0 = d(r_{X_0 Y_0})$ (such r_{X_0} , r_{Y_0} and $r_{X_0 Y_0}$ can always be found due to Lemma 1.3.6). The indexing subset is again $\{0, 1, \dots, n\}$ and is omitted.

Proposition 1.3.9. Setting

$$a_{0,\dots,n} := (\Delta a + a \circ f - g \circ' a)r_{X_0} + (\Delta g + g \circ g)r_{X_0 Y_0}$$

indeed gives $d(a_{0,\dots,n}) = \Delta a + a \circ f + g \circ a$, thus this lifts the morphism.

Proof. We start from observing that $g \circ a = g \circ' a + g_{0,\dots,n} a_0$ and we can insert our value of $g_{0,\dots,n}$. This gives

$$\Delta a + a \circ f - g \circ a = \Delta a + a \circ f - g \circ' a - (\Delta a + a \circ f - g \circ' a)\bar{a}_0 a_0 + (\Delta g + g \circ g)r_{Y_0} a_0.$$

We know that $d(\Delta a + a \circ f - g \circ' a) = (\Delta g + g \circ g)a_0$, so

$$d((\Delta a + a \circ f - g \circ' a)r_{X_0}) = (\Delta g + g \circ g)a_0 r_{X_0} + (\Delta a + a \circ f - g \circ' a)(\bar{a}_0 a_0 - 1).$$

Then we are left to notice that indeed

$$(\Delta g + g \circ g)(a_0 r_{X_0} - r_{Y_0} a_0) = d((\Delta g + g \circ g)r_{X_0 Y_0})$$

and thus we have constructed the lift. \square

Having Lemma 1.3.2 in our possession, we are left to notice that the degree 0 components of the lift are a_i , which are homotopy equivalences in \mathbf{A} as a was a homotopy equivalence in $M_n F(\mathbf{A})$. Thus, we have proved the following theorem.

Theorem 1.3.10. For all n , matching maps $F_n(\mathbf{A}) \rightarrow M_n F(\mathbf{A})$ are Dwyer-Kan fibrations. Consequently, $F_\bullet(\mathbf{A})$ is Reedy fibrant.

Remark 1.3.11. In [Hol], the Dwyer-Kan fibrancy of the matching maps was proved for the case when \mathbf{A} is pretriangulated, by a strategy involving contraction of the cones. This strategy can in fact be performed in the case of arbitrary \mathbf{A} , which we demonstrate in Appendix 1.A.

Remark 1.3.12. In the framework of ∞ -local systems, the meaning of Reedy fibrancy is the following: if a is a homotopy equivalence between two ∞ -local systems on the simplex boundary, one of which was restricted from the simplex, then this homotopy equivalence can be lifted to a homotopy equivalence between two ∞ -local systems on the simplex.

1.A An alternative proof of Reedy fibrancy

We now present a proof of Theorem 1.3.10 that does not rely on Lemma 1.3.2.

1.A.1 Contraction of cones and pretriangulated envelopes

We have to verify that lift of Proposition 1.3.9 is a homotopy equivalence in $F_n(\mathbf{A})$. While an explicit computation might be possible, it appears to be very cumbersome even in the case $n = 1$ (see [Sho], Lemma 3.5). There exists, however, a strategy involving contractions of cones (see [Tab2]).

Definition 1.A.1. For an object X in some DG-category \mathbf{A} , its contraction is $b_X \in \mathbf{A}^{-1}(X, X)$ with $d(b_X) = 1_X$.

Lemma 1.3.6 precisely states that for any homotopy equivalence \mathbf{A} , you can construct a contraction of its cone in $\text{Mod } \mathbf{A}$. However, one does not have to go as far as the whole category of DG-modules. Following [Dri], recall the construction of the pretriangulated envelope.

Definition 1.A.2. For a DG-category \mathbf{A} , its pretriangulated envelope $\text{Pretr}(\mathbf{A})$ has one-sided twisted complexes as objects – namely, those are formal expressions $(\bigoplus_{i=1}^n C_i[r_i], q)$, where C_i are objects of \mathbf{A} , r_i are integers and q is a set of morphisms $q_{ij} \in (\mathbf{A}(C_j, C_i)[r_i - r_j])^1$ subject to $q_{ij} = 0$ for $i \geq j$ and $dq + q \circ q = 0$. The morphisms are given by

$$\text{Pretr}(\mathbf{A})\left(\left(\bigoplus_{i=1}^n C_i[r_i], q\right), \left(\bigoplus_{j=1}^m C'_j[r'_j], q'\right)\right) = \bigoplus_{i,j} \mathbf{A}(C_j, C'_i)[r'_i - r_j].$$

That is, a degree k morphism $f: (\bigoplus_{i=1}^n C_i[r_i], q) \rightarrow (\bigoplus_{i=1}^m C'_i[r'_i], q')$ is a set of components $f_{ij} \in (\mathbf{A}(C_j, C'_i)[r'_i - r_j])^k$, with matrix multiplication for composition and with differential given by

$$d_{TC}(f) = d(f) + q' \circ f - (-1)^k f \circ q.$$

There are natural fully faithful embeddings $\mathbf{A} \hookrightarrow \text{Pretr}(\mathbf{A}) \hookrightarrow \text{Mod } \mathbf{A}$. For any $f \in Z^0(\mathbf{A}(X, Y))$, its cone is an object of $\text{Pretr}(\mathbf{A})$ defined as $\text{Cone}(f) := (Y \oplus X[1], q)$ with $q_{12} = f$ (this is compatible with the embedding $\text{Pretr}(\mathbf{A}) \hookrightarrow \text{Mod } \mathbf{A}$). We say that \mathbf{A} already has all the cones if $\text{Cone}(f)$ is always isomorphic to some object in the image of the embedding $\mathbf{A} \hookrightarrow \text{Pretr}(\mathbf{A})$. It can be checked that $\text{Pretr}(\mathbf{A})$ has all the cones.

Note that for DG-categories that have all the cones, we can now prove the following lemma.

Lemma 1.A.3. If \mathbf{A} has all the cones, then the matching maps $m_n: F_n(\mathbf{A}) \rightarrow M_n F(\mathbf{A})$ are fibrations.

Proof. We are left to check that if \tilde{a} is a closed lift of a homotopy equivalence $a: (X, f_{\leq n}) \rightarrow (Y, g)$, then \tilde{a} is a homotopy equivalence in $F_n(\mathbf{A})$. We notice that if \mathbf{A} has all the cones, then $F_n(\mathbf{A})$ and $M_n F(\mathbf{A})$ also have all the cones. So $\text{Cone}(a)$ is an object of $M_n F(\mathbf{A})$ which (by Lemma 1.3.6) has a

contraction b . Note that for any functor, the induced functor on pretriangulated envelopes respects cones, so $m_n(\text{Cone}(\tilde{a})) = \text{Cone}(a)$. Lifting b to a contraction of $\text{Cone}(\tilde{a})$ will then show that \tilde{a} is a homotopy equivalence. And indeed, any contraction can be lifted along m_n . Let b be a contraction of $(X, f_{\leq n})$. The lift, as shown in [Hol], is obtained by setting

$$b_{0,\dots,n} = b_0(\Delta b + b \circ f + f \circ b).$$

□

We now show how the assumption of \mathbf{A} having all the cones can be omitted. In [Tab2], this was done for the case $n = 1$ via a quasiequivalence $\text{Pretr}(F_1(\mathbf{A})) \simeq F_1(\text{Pretr}(\mathbf{A}))$.

1.A.2 Proof of Theorem 1.3.10

Consider the following commutative square, where the horizontal arrows are fully faithful embeddings given by compositions of F_n (respectively $M_n F$) with natural embeddings $\mathbf{A} \hookrightarrow \text{Pretr}(\mathbf{A})$:

$$\begin{array}{ccc} F_n(\mathbf{A}) & \hookrightarrow & F_n(\text{Pretr}(\mathbf{A})) \\ \downarrow & & \downarrow \\ M_n F(\mathbf{A}) & \hookrightarrow & M_n F(\text{Pretr}(\mathbf{A})) \end{array}$$

For a homotopy equivalence $a: (X, f_{\leq n}) \rightarrow (Y, g)$ in $M_n F(\mathbf{A})$, we have constructed in Proposition 1.3.9 its closed lift along the left vertical arrow. Under embeddings, this is also a legitimate lift along the right vertical arrow. As the category $\text{Pretr}(\mathbf{A})$ has all the cones, we know from Lemma 1.A.3 that any closed lift of a homotopy equivalence is a homotopy equivalence. So we are left to observe that embeddings respect homotopy equivalences, and that if a morphism is a homotopy equivalence in the larger category then it is also a homotopy equivalence in the smaller category. This concludes the proof.

1.B Erratum

Contrary to what was stated in our paper as published in HHA at page 2, the proof of Proposition 3.3 in [Tab2] did not contain any mathematical inaccuracies or flaws. Rather, it was a question of exposition: a trivial computation was omitted without explicitly mentioning the fact, and this led the author of [Hol] to wrong conclusions. The proof in [Hol] thus indeed contained a gap that we fixed here.

Bibliography

- [AØ] S. Arkhipov, S. Ørsted. “Homotopy limits in the category of dg-categories in terms A_∞ comodules”. ArXiv preprint 1812.03583, (2018).
- [BHW] J. Block, J. V. Holstein, and Z. Wei. “Explicit homotopy limits of dg categories and twisted complexes”. *Homology, Homotopy and Applications* 19(2), (2017), pp. 343–371.
- [Dri] V. Drinfeld. “DG quotients of DG categories”. *J. Algebra* 272(2), (2004), 643-691.
- [Fao] G. Faonte. “ A_∞ -functors and homotopy theory of dg-categories”. *J. Noncommut. Geom.* 11(3), (2017), 957-1000.
- [Hir] Ph. S. Hirschhorn. “Model Categories and Their Localizations”. *AMS Mathematical Surveys and Monographs*, Vol. 99, (2003).
- [Hol] J. Holstein. “Properness and simplicial resolutions for the model category dgCat ”. *Homology Homotopy Appl.*, 16(2):263–273, (2014).
- [Hov] M. Hovey. “Model categories”. Volume 63 of *Mathematical Surveys and Monographs*. American Mathematical Society, Providence, RI, (1999).
- [Kon] M. Kontsevich. “Lectures at ENS, Paris, Spring 1998: notes taken by J.Bellaïche, J.-F.Dat, I.Marin, G.Racinet and H.Randriambololona”, unpublished.
- [Lef] K. Lefèvre-Hasegawa. “Sur les A_∞ catégories”. PhD thesis. L’Université Paris 7. (2003)
- [Sho] B. Shoikhet. “On the twisted tensor product of small dg categories”. ArXiv preprint 1803.01191, (2018).
- [Tab] G. Tabuada. “Une structure de categorie de modeles de Quillen sur la categorie des dg-categories”. *C. R. Acad. Sci. Paris. I* 340, (2004).
- [Tab2] G. Tabuada. “Homotopy theory of dg categories via localizing pairs and Drinfeld’s dg quotient”. *Homology Homotopy Appl.* Volume 12, Number 1 (2010), 187-219.

[Toë] B. Toën. “The homotopy theory of dg-categories and derived Morita Theory”. *Invent. Math.*, Volume 167, Number 3, (2007), 615-667.

Chapter 2

Homotopy characters as a homotopy limit

2.1 Introduction

The note, co-authored with Sergey Arkhipov, is devoted to an explicit calculation of a homotopy limit for a certain cosimplicial diagram in the model category of DG-categories. Recall that a general construction for representatives of such derived limits was given in the papers [BHW] and [AØ2]. Below we consider a baby example where the answer appears to be both explicit and meaningful.

Let us illustrate our answer in an important special case. Take the Hopf algebra A of regular functions on an affine algebraic group G . The cosimplicial system we consider is given basically by the simplicial scheme X_\bullet realizing BG . Notice that if we considered the DG-categories of quasicoherent sheaves on X_n and passed to the homotopy limit, the resulting DG-category would have been a model for the derived category of quasicoherent sheaves on the classifying space BG which is known to be equivalent to the derived category of representations of G .

Our task is different: we treat the (DG)-algebras of regular functions on X_n as DG-categories with one object and consider the corresponding homotopy limit. We prove that it is equivalent to an interesting subcategory in the category of representations up to homotopy introduced earlier by Abad, Crainic, and Dherin (see [ACD]): the (non-additive) DG-category of *characters up to homotopy* of the group G also known as the DG-category of Maurer-Cartan elements in the Cobar construction for the coalgebra of functions on G .

The obtained answer illustrates a delicate issue: taking the homotopy

limit of a diagram of DG-categories does not commute with the (infinity-) functor $A \mapsto \mathrm{DGMod}(A)$. Namely, passing to the categories of modules levelwise and then considering the homotopy limit would have produced the DG-category of quasicoherent sheaves on BG . Yet applying $\mathrm{DGMod}(\dots)$ to the DG-category of homotopy characters we get a different category.

However, if we replace the *derived categories* of DG-modules by the coderived ones, this difference of the answers vanishes: the coderived category of DG-modules over the DG-category of homotopy characters for G is quasi-equivalent to the coderived category of DG-modules over endomorphisms of the trivial character. By Positselski Koszul duality, the latter category is quasi-equivalent to the coderived category of representations for G .

We conclude the paper by constructing an associative tensor product of objects in the DG-category of characters up to homotopy (in the generality of a DG-Hopf algebra, since we never use commutativity of the algebra in our considerations). Recall that Abad, Crainic and Dherin also constructed a homotopy monoidal structure on their category of representations up to homotopy (see [ACD]). Our answer agrees with theirs. We interpret this answer in terms of Kadeishvili's multibraces.

Notice that there is no expectation to produce a honest associative tensor product of morphisms before passing to the homotopy category. Instead we plan to produce a homotopy coherent data descending to this structure after taking homology. This is work in progress.

Organization of the paper

In Section 2.2 we give preliminaries on model categories, DG-modules and Cobar-constructions. In Section 2.3 we introduce the cosimplicial system of interest, state its homotopy limit in the category of DG-algebras, and give the first description of its homotopy limit in the category of DG-categories. In Section 2.4 we interpret this result in terms of Maurer-Cartan elements in Cobar-construction. In Section 2.5 we explain the coMorita equivalence between the homotopy limit taken in the category of DG-algebras and the homotopy limit taken in the category of DG-categories. In Section 2.6 we reinterpret the homotopy limit category in terms of representations up to homotopy in the sense of [AC]. In Section 2.7 we discuss the monoidal structure (as in [ACD]) and how it is connected to Kadeishvili's multibraces. Finally in Appendix 2.A we provide a detailed computation of the same homotopy limit in the category of DG-algebras, by means of simplicial resolutions.

Acknowledgements

We are grateful to Leonid Positselski for many enlightening comments, in particular for sharing the proof of Lemma 2.5.4 with us. The second author would like to thank Timothy Logvinenko for inviting her to present an early version of this project at GiC seminar in Cardiff, and Ryszard Nest for useful discussions. The second author was supported by the Danish National Research Foundation through the Centre for Symmetry and Deformation (DNRF92).

2.2 Preliminaries

2.2.1 Model categories involved

The category of DG-algebras $\text{DGA}(\mathbf{k})$ is equipped with projective model structure which is right-transferred from the category of chain complexes along the adjunction “tensor algebra functor/forgetful functor”. The weak equivalences are the quasiisomorphisms, the fibrations are the surjections, and the cofibrations are defined by the left lifting property.

In this paper, we mostly work with more general objects. Recall that a DG-category is by definition a category enriched over the monoidal category of complexes of vector spaces, denoted by $\text{DGVect}(\mathbf{k})$. Every DG-algebra is a DG-category with one object. We denote the category of small DG-categories and DG-functors over a field \mathbf{k} by $\text{DGCat}(\mathbf{k})$. Tabuada constructed a model category structure on $\text{DGCat}(\mathbf{k})$, with weak equivalences being quasi-equivalences of DG-categories (see [Tab]).

For an arbitrary model category \mathbf{C} , the category $\mathbf{C}^{\Delta^{opp}}$ is equipped with Reedy model structure (see [Hov] or [Hir]).

2.2.2 DG-modules

A DG-functor from a DG-category \mathbf{A} with values in the DG-category $\text{DGVect}(\mathbf{k})$ is called an \mathbf{A} -DG module. Notice that this agrees with the definition of a DG-module over a DG-algebra. The DG-category of \mathbf{A} -DG-modules is denoted by $\text{DGMod}(\mathbf{A})$.

2.2.3 Cobar-constructions

In our paper we will be dealing with two sorts of Cobar-construction for DG-coalgebras. In the first construction, the complex happens to be acyclic whenever the coalgebra is counital; conceptually it is a cofree resolution of the coalgebra as a comodule over itself. In the second construction, the

coaugmentation of the coalgebra provides boundary terms for the differential; the resulting complex is quasiisomorphic to what is known as the *reduced* Cobar-construction, and it is similar to the standard complex computing $\text{Cotor}^C(k, k)$. Note however, that in this note we are using products not sums. Let us give the definitions and the notation.

Definition 2.2.1. Let C be (not necessarily counital or coaugmented) DG-coalgebra. As a graded vector space,

$$\text{Cobar}(C) = \widehat{T}(C[-1]) = \prod_{i=0}^{\infty} C[-1]^{\otimes i}$$

The multiplication is that of a complete tensor algebra. The differential is given by $d = d_C + \Delta$ on generators and extends to the rest of the algebra by Leibniz rule.

Remark 2.2.2. If C is counital, this Cobar construction is actually acyclic, with counit giving rise to a contraction.

If C is coaugmented with coaugmentation $1: k \rightarrow C$, then there is the following modification.

Definition 2.2.3. As a graded algebra, $\text{Cobar}_{\text{coaug}}(C) \simeq \widehat{T}(C[-1])$ again. The differential is given by $d = d_C + \Delta + 1 \otimes \text{id} - \text{id} \otimes 1$ on generators and extends to the rest of the algebra by Leibniz rule.

Remark 2.2.4. In the coaugmented case, 1_C is a Maurer-Cartan element in $\text{Cobar}(C)$, and the differential in the later construction is the differential in the former construction twisted by this Maurer-Cartan element.

2.3 The cosimplicial system

Let $(A, m, 1, \Delta, \epsilon)$ be a (unital, counital) DG-bialgebra. Informally, in the case when A is commutative, we should view it as the algebra of functions on a derived affine algebraic group scheme. Notice however that we never use commutativity of A in our main statements.

Consider the cosimplicial system A^\bullet of DG-algebras corresponding to the classifying space construction:

$$k \rightrightarrows A \rightrightarrows A^{\otimes 2} \quad \dots \quad (2.1)$$

Let ∂_n^i denote the face map $A^{\otimes n} \rightarrow A^{\otimes n+1}$ and s_n^i denote the degeneracy map $A^{\otimes n} \rightarrow A^{\otimes n-1}$. Then in the system above, faces and degeneracies are given by

$$\partial_n^i = \begin{cases} 1 \otimes \text{id}^{\otimes n} & i = 0 \\ \text{id}^{\otimes i-1} \otimes \Delta \otimes \text{id}^{\otimes n-i} & 0 < i < n + 1 \\ \text{id}^{\otimes n} \otimes 1 & i = n + 1 \end{cases}$$

$$s_n^i = \text{id}^{\otimes i} \otimes \epsilon \otimes \text{id}^{\otimes n-i-1}$$

There are several homotopy limit computations that can be done in relation to system (2.1):

- (a) One can compute the homotopy limit in the category of DG-algebras
- (b) One can view every DG-algebra as a DG-category with one object and compute the homotopy limit in the category of DG-categories
- (c) One can apply DG-Mod functor and compute the homotopy limit of this new system of DG-categories.

The answer to (a) is folklore. The homotopy limit of the cosimplicial system is given by the reduced Cobar-construction of the corresponding coaugmented DG-coalgebra. We were not able to locate the proof of this statement in the literature, thus we reproduce it in Appendix 2.A.

In this paper we discuss mainly the answer to (b). The comparison between (b) and (c) is discussed in Section 2.5.

In the papers [BHW] and [AØ2] the authors realized homotopy limits in $\text{DGCat}(\mathbf{k})^{\Delta^{\text{op}}}$ as derived totalizations. Below we cite Prop. 4.0.2 from [AØ2], with formulas written in their most explicit form. To simplify the notation, we denote by $\partial^{(i_1 \dots i_k)}$ an inclusion with image i_1, \dots, i_k .

Theorem 2.3.1. For \mathbf{C}^\bullet a cosimplicial system of DG categories, an object of $\text{holim } \mathbf{C}$ is the data of $(X, a = \{a_i\}_{i \geq 1})$, where X is an object of \mathbf{C}^0 and $a_i \in \text{Hom}_{\mathbf{C}^i}^{1-i}(d^{(0)}X, d^{(n)}X)$ with a_1 homotopy invertible and subject to

$$\begin{aligned} d(a_n) = & - \sum_{k=1}^{n-1} (-1)^{n-k} \partial^{(k \dots n)}(a_{n-k}) \circ \partial^{(0 \dots k)}(a_k) \\ & + \sum_{k=1}^{n-1} (-1)^{n-k} \partial^{(0 \dots \hat{k} \dots n)}(a_{n-1}). \end{aligned} \tag{2.2}$$

The complex of morphisms between (X, a) and (Y, b) in degree m is given by

$$\text{Hom}^m((X, a), (Y, b)) = \prod_{i=0}^{\infty} \text{Hom}_{\mathbf{C}^i}^{m-i}(\partial^{(0)}(X), \partial^{(i)}(Y))$$

where we read $\partial^{(0)}: \mathbf{C}^0 \rightarrow \mathbf{C}^0$ as $\text{id}_{\mathbf{C}^0}$. For $f = \{f_i\} \in \text{Hom}^m((X, a), (Y, b))$

its differential is given by

$$\begin{aligned}
d(f)_n &= d(f_n) + \sum (-1)^{n-k} \partial^{(k\dots n)}(f_{n-k}) \circ \partial^{(0\dots k)}(a_k) \\
&\quad - \sum_{k=1}^{n-1} (-1)^{m(n-k+1)} \partial^{(k\dots n)}(b_{n-k}) \circ \partial^{(0\dots k)}(f_k) \\
&\quad + \sum_{k=1}^{n-1} (-1)^{n-k+m} \partial^{(0\dots k\dots n)}(f_{n-1}).
\end{aligned} \tag{2.3}$$

For $f \in \text{Hom}^m((X, a), (Y, b))$ and $g \in \text{Hom}^l((Y, b), (Z, c))$, their composition composition is given by

$$(g \circ f)_n = \sum_{k=0}^n (-1)^{m(n-k)} \partial^{(k\dots n)}(g_{n-i}) \circ \partial^{(0\dots k)}(f_k). \tag{2.4}$$

□

We now apply these formulas to the cosimplicial system (2.1). Note that while each category in (2.1) has a single object, this would not hold for the homotopy limit, where the data of an object includes morphisms. Denote $\text{holim } A^\bullet =: \mathfrak{A}$.

Theorem 2.3.2. An object a in \mathfrak{A} is an infinite sequence $\{a_i\}_{i \geq 1}$ with $a_i \in (A^{\otimes i})^{1-i}$ and a_1 homotopy invertible, subject to relations

$$\begin{aligned}
d(a_1) &= 0 \\
d(a_2) &= a_1 \otimes a_1 - \Delta(a_1) \\
&\dots \\
d(a_n) &= - \sum_{k=1}^{n-1} (-1)^{n-k} a_{n-k} \otimes a_k \\
&\quad + \sum_{k=1}^{n-1} (-1)^{n-k} (\text{id}^{\otimes k-1} \otimes \Delta \otimes \text{id}^{\otimes n-k-1})(a_{n-1}) \\
&\dots
\end{aligned} \tag{2.5}$$

A morphism $f: a \rightarrow b$ of degree m is also an infinite sequence $\{f_n\}_{n \geq 0}$ with $f_n \in (A^{\otimes n})^{-n}$, with differential given by

$$\begin{aligned}
d(f)_n &= d(f_n) + \sum_{k=1}^{n-1} (-1)^{n-k} a_k \otimes f_{n-k} - \sum_{k=1}^{n-1} (-1)^{m(n-k+1)} f_i \otimes b_{n-k} \\
&\quad + \sum_{k=1}^{n-1} (-1)^{n-k+m} (\text{id}^{\otimes k-1} \otimes \Delta \otimes \text{id}^{\otimes n-k-1})(f_{n-1})
\end{aligned} \tag{2.6}$$

and composition given by

$$(g \circ f)_n = \sum_{k=0}^n (-1)^{m(n-k)} g_n \otimes f_{n-k} \quad (2.7)$$

Proof. This is a straightforward application of Theorem 2.3.1. As in the theorem, denote an object of the homotopy limit by (X, a) . In our cosimplicial system (2.1), $A^0 = \mathbf{k}$ has only one object, so $X = *$. Then the identities (2.2) translate to (2.5), the formula for the differential (2.3) corresponds to (2.6), and the formula for the composition corresponds to (2.7). \square

Below we present several interpretations of this data.

2.4 Maurer-Cartan elements in Cobar

We interpret the homotopy limit category \mathfrak{A} in terms of the Cobar construction for the DG-coalgebra A .

Proposition 2.4.1. The objects of \mathfrak{A} are exactly the Maurer-Cartan elements of $\text{Cobar}(A)$, with one extra condition that their first component is homotopy invertible.

Proof. The Maurer-Cartan equation $dx + \frac{1}{2}[x, x] = 0$ translates precisely into the formulas (2.5). \square

In any DG algebra A , a Maurer-Cartan element c allows to twist the differential:

$$d_c(a) = d(a) + [c, a]$$

Denote the new algebra by ${}_c C_c$. For two Maurer-Cartan elements c_1 and c_2 , denote by ${}_{c_1} C_{c_2}$ a complex obtained by considering A with the new differential

$$d_{(c_1, c_2)}(a) = d(a) + c_1 a - (-1)^{|a|} a c_2. \quad (2.8)$$

This will not be a DG-algebra anymore (for the lack of multiplication satisfying the Leibniz rule), but it will be a ${}_{c_1} C_{c_1} - {}_{c_2} C_{c_2}$ DG-bimodule.

Proposition 2.4.2. In the DG-category \mathfrak{A} , the complex of morphisms

$$\mathfrak{A}(a, b) = {}_a \text{Cobar}(A)_b.$$

Proof. The formula (2.8) for the twisted differential corresponds precisely to the formula (2.6). \square

So as a graded vector space, every $\mathfrak{A}(a, b)$ is equal to $\text{Cobar}(A)$.

Proposition 2.4.3. Under this assignment, the composition $\mathfrak{A}(a, b) \otimes \mathfrak{A}(b, c) \rightarrow \mathfrak{A}(a, c)$ corresponds to the multiplication in $\text{Cobar}(A)$.

Proof. This is the formula (2.7). \square

In $\text{Cobar}(A)$, there is a distinguished nontrivial Maurer-Cartan element, namely, $1_A \in A$. Denote the corresponding object of \mathfrak{A} by \mathbb{I} . Its endomorphisms are ${}_{1_A}\text{Cobar}(A)_{1_A} \simeq \text{Cobar}_{\text{coaug}}(A)$. As explain in Appendix 2.A, this is a model for the homotopy limit of our cosimplicial system but taken in the category $\text{DGA}(\mathbf{k})$.

Recall the notion of gauge equivalence for Maurer-Cartan elements.

Definition 2.4.4. In a DG-algebra A , the gauge action of a degree 0 invertible element f on a Maurer-Cartan element a is given by

$$f \cdot a = f a f^{-1} + f d(f^{-1}).$$

One checks that this is again a Maurer-Cartan element. Two Maurer-Cartan elements are called gauge equivalent if they belong to the same orbit of gauge action.

Proposition 2.4.5. Gauge equivalent Maurer-Cartan elements of $\text{Cobar}(A)$ are strictly isomorphic as objects of \mathfrak{A} .

Proof. The very same invertible element provides the closed isomorphism when viewed as an element of the Hom-complex. Upon explicitly checking closedness, the rest follows from composition being reinterpreted as the multiplication in $\text{Cobar}(A)$. \square

2.5 CoMorita equivalences

For any DG algebra A and Maurer-Cartan elements a and b , it holds that

$${}_a A_b \otimes_{{}_b A_b} {}_b A_a = {}_a A_a,$$

so ${}_a A_b$ and ${}_b A_a$ are inverse bimodules on the nose. This gives an expectation for a Morita equivalence between \mathfrak{A} and $\text{Cobar}(A)$. However, sometimes these bimodules may be acyclic, and derived tensoring by an acyclic bimodule cannot induce an equivalence of derived categories. To make things work, one needs to consider not derived categories but instead Positselski's coderived categories, where the class of acyclic objects is replaced by a smaller class of coacyclic objects. For detailed exposition see [Pos].

Definition 2.5.1. For a DG algebra A , the subcategory $\text{CoAcycl} \subset \text{Ho}(A)$ is the smallest triangulated subcategory containing totalizations of exact triples of modules and closed with respect to infinite direct sums.

Definition 2.5.2. The coderived category $D^{\text{co}}(A)$ is defined as the Verdier quotient of the homotopy category $\text{Ho}(A)$ by the full subcategory CoAcycl .

For the proof of the next lemma, recall the notion of CDG-algebras and their morphisms.

Definition 2.5.3. A curved DG-algebra (for brevity, a CDG-algebra) is a graded algebra A equipped with a degree 1 derivation d and a closed curvature element $h \in A^2$, satisfying

$$d^2(x) = [h, x]$$

A morphism of CDG-algebras $A \rightarrow B$ is a pair (f, b) where $f : B \rightarrow C$ is a multiplicative map and $b \in B^1$ is the change of curvature, i.e. they satisfy

$$f(d_A(x)) = d_B(f(x)) + [a, x] \quad (2.9)$$

$$d(h_A) = h_B + d_B(b) + b^2 \quad (2.10)$$

The composition of CDG-morphisms is

$$(g, c) \circ (f, b) = (g \circ f, c + g(b))$$

A DG-algebra can be viewed as a CDG-algebra with zero curvature, but the inclusion $\text{DGA}(\mathbf{k}) \hookrightarrow \text{CDGA}(\mathbf{k})$ is not full.

Lemma 2.5.4. For any DG algebra A , there is an equivalence of coderived categories

$$D^{co}({}_a A_a) \simeq D^{co}({}_b A_b)$$

Proof. ${}_a A_a$ and ${}_b A_b$ are isomorphic as CDG-algebras (with zero curvature). The CDG-isomorphism ${}_a A_a \rightarrow {}_b A_b$ is given by $(id, -a)$, where (2.9) corresponds to the formula for twisting the differential, and (2.10) corresponds to the Maurer-Cartan equation for a . Coderived categories are preserved under CDG-isomorphisms. \square

Remark 2.5.5. Compare the calculation above of the explicit representative for the homotopy limit of the DG-algebras considered as DG-categories with the following.

1. In the paper [AØ2] the authors solve a similar problem for the homotopy limit of the derived categories of DG-modules over the DG-algebras in the cosimplicial system. The answer can be interpreted as the derived category of DG-modules over the reduced Cobar construction for the original DG-Hopf algebra (Theorem 4.1.1).
2. Conjecturally the statement remains true also for the homotopy limit of the corresponding enhanced coderived categories: one obtains the coderived category of DG-modules over the Cobar construction for the original DG-Hopf algebra.

Now take the category of DG-modules over the DG-category of Maurer-Cartan elements \mathfrak{A} . While its derived category obviously differs from the derived category that appears in (1), its *coderived* category is quasi-equivalent to the answer in (2).

We will now make this precise. Let B be an arbitrary DG-algebra.

Definition 2.5.6. Maurer-Cartan DG-category $\text{MC}(B)$ has the Maurer-Cartan elements of B as morphisms, and Hom-complexes are given by

$$\text{Hom}_{\text{MC}(B)}(a, b) = {}_a B_b.$$

The definitions 2.5.1 and 2.5.2 can be directly generalized from DG-algebras to DG-categories, so for a DG-category \mathcal{C} one can consider a category $D^{co}(\mathcal{C})$.

Proposition 2.5.7. For any DG-algebra B and a Maurer-Cartan element $b \in B$, there is an equivalence of categories

$$D^{co}(\text{MC}(B)) \simeq D^{co}({}_b B_b).$$

Proof. This is a statement of the type “modules over a connected groupoid are the same as modules over endomorphisms of an object in this groupoid”, with a similar proof.

Let

$$F: \text{DGMod}(\text{MC}(B)) \rightarrow \text{DGMod}({}_b B_b)$$

be given by restricting to b ,

$$F(M) = M(b).$$

Define

$$G: \text{DGMod}({}_b B_b) \rightarrow \text{DGMod}(\text{MC}(B))$$

by setting, for $a \in \text{MC}(b)$,

$$G(N)(a) = {}_a B_b \otimes_{{}_b B_b} N$$

and for $f \in \text{MC}(B)(a_1, a_2) = {}_{a_1} B_{a_2}$ let the corresponding map

$$G(f): {}_a B_b \otimes_{{}_b B_b} N \rightarrow {}_a B_b \otimes_{{}_b B_b} N$$

be simply multiplication by f on the left. We would like to check that these functors induce an equivalence on coderived categories. First we check that they give an equivalence at the level of DG-categories. It is clear that $FG = \text{Id}_{\text{DGMod}({}_b B_b)}$. For $M \in \text{DGMod}(\text{MC}(B))$ and $a \in \text{MC}(B)$, we have

$$GF(M)(a) = {}_a B_b \otimes_{{}_b B_b} M(b).$$

Then the isomorphism $GF(M) \rightarrow M$ is given at a by

$$f \otimes m \mapsto M(f)(m)$$

and its inverse is

$$m \mapsto 1 \otimes M(1)(m)$$

where $1 \in {}_a B_b$ is viewed as a map $a \rightarrow b$.

We are left to verify that F and G preserve coacyclic objects. To do so, they need to preserve exact triples, and commute with totalizations, cones and infinite direct sums. For DG-modules over a DG-category, exactness is checked objectwise, and totalizations, cones and direct sums are also formed objectwise. Thus for F the statements hold trivially. For G , the statements about totalizations, cones and sums hold trivially, and the statement that G respects exact triples follows from flatness of ${}_b B_b$ -modules ${}_a B_b$. They are indeed flat, because their underlying graded modules are just free of rank 1, and flatness does not depend on the differential. \square

Note that in particular this proposition establishes a coMorita equivalence between $\text{MC}(B)$ and B itself, as B can be seen as the endomorphism algebra of $0 \in \text{MC}(B)$. Also note that Lemma 2.5.4 follows from this proposition, but we keep its proof via CDG-isomorphism because it is conceptually correct.

Corollary 2.5.8. There is an equivalence of coderived categories

$$\text{D}^{co}(\mathfrak{A}) \simeq \text{D}^{co}(\text{Cobar}_{\text{coaug}}(A)).$$

\square

Here we are considering the reduced Cobar construction for the sake of comparing with the result in [AØ2] and with the computation in $\text{DGA}(\mathbf{k})$. Reduced and non-reduced Cobar constructions are coMorita equivalent by Proposition 2.5.7 (though not Morita equivalent).

2.6 Homotopy characters

Recall the notion of an A_∞ -comodule over a DG-coalgebra (A_∞ -comodules can be considered over any A_∞ -coalgebra, but this generality will not be needed). For detailed exposition see [AØ2] or, on the dual side, [Kel].

Definition 2.6.1. The A_∞ -comodule structure on a graded vector space M over a DG-coalgebra C is a DG-module structure on $M \otimes \text{Cobar}(C)$ over $\text{Cobar}(C)$. Explicitly, it is given by a sequence of coaction maps, for all $n \geq 1$,

$$\mu_n: M \rightarrow C^{\otimes n-1} \otimes M$$

with μ_n of degree $1 - n$ and all the collection of maps together satisfying the A_∞ -identities for each $n \geq 1$:

$$\begin{aligned} & (-1)^{n-1} \sum_{i=0}^n (\text{id}^{\otimes i} \otimes d \otimes \text{id}^{\otimes n-i-1}) \mu_n + \mu_n d \\ & + \sum_{i=1}^{n-1} (-1)^i (\text{id}^{\otimes i} \otimes \mu_{n-i}) \mu_i + \sum_{i=0}^{n-2} (-1)^i (\text{id}^{\otimes i} \otimes \Delta \otimes \text{id}^{\otimes n-i-2}) \mu_{n-1} = 0 \end{aligned} \quad (2.11)$$

Definition 2.6.2. For two A_∞ -comodules over a DG-algebra A , the Hom-complex between them is defined by

$$\text{Hom}^m(M, N) = \prod_{i=0}^{\infty} \text{Hom}_k^{m-i}(M, C^{\otimes i} \otimes N)$$

with differential

$$\begin{aligned} d(f)_n &= \sum_{k=1}^{n-2} (-1)^{n-k} (\text{id}^{\otimes n-k-2} \otimes \Delta \otimes \text{id}^{\otimes k}) f_{n-1} \\ &+ \sum_{i=0}^{n-1} (-1)^i (\text{id}^{\otimes i} \otimes \mu_{n-i}) f_{i+1} + \sum_{p=1}^n (-1)^{p|f|} (\text{id}^{\otimes p-1} \otimes f_{n-p+1}) \mu_p \end{aligned} \quad (2.12)$$

The composition is given by

$$(g \circ f)_n = \sum_{l=1}^n (-1)^{|g|(l-1)} (\text{id}^{\otimes l-1} \otimes g_{n-l+1}) f_l \quad (2.13)$$

Proposition 2.6.3. The DG-category \mathfrak{A} is isomorphic to the subcategory of 1-dimensional (non-counital) A_∞ -comodules over A .

Proof. For $M = \mathbf{k}$ a structure map $\mu_n: \mathbf{k} \rightarrow A^{\otimes n} \otimes \mathbf{k}$ is indeed given by an element $a_n \in A^{\otimes n}$. The A_∞ -relations (2.11) correspond to the formulas (2.5). The formula for the differential (2.12) corresponds to (2.6), and the formula for the composition (2.13) corresponds to (2.7). \square

Note that if A were the coalgebra of functions on some group, then comodules over this coalgebra would correspond to representations of the group. This leads us to the following interpretation of our data. A_∞ -comodules over a Hopf DG-algebra can be viewed as *representations up to homotopy* of the corresponding derived group. Within this category, one-dimensional comodules correspond to *homotopy characters*. Group representations up to homotopy have been defined and studied (for non-derived Lie groupoids) by Abad-Crainic in [AC].

In the case when A is a Hopf algebra of functions on a group (concentrated in degree 0), our category has honest characters (i.e. 1-dimensional representations) as objects, and the Hom complexes compute Exts between them.

Example 2.6.4. Let G be the group of invertible upper triangular 2×2 matrices over \mathbb{C} . Consider the following functions:

$$x \begin{pmatrix} a & c \\ 0 & b \end{pmatrix} = a; \quad y \begin{pmatrix} a & c \\ 0 & b \end{pmatrix} = b; \quad z \begin{pmatrix} a & c \\ 0 & b \end{pmatrix} = c.$$

The Hopf algebra of regular functions on G is $\mathbb{C}[x^{\pm 1}, y^{\pm 1}, z]$, with comultiplication

$$\Delta(x^{\pm 1}) = x^{\pm 1} \otimes x^{\pm 1};$$

$$\Delta(y^{\pm 1}) = y^{\pm 1} \otimes y^{\pm 1};$$

$$\Delta(z) = x \otimes z + z \otimes y.$$

1 and xy^{-1} are two characters of G . We have $\text{Ext}^1(1, xy^{-1}) = \mathbb{C}$. In our Holim category, the Hom complex between 1 and xy^{-1} is

$$\mathbb{C} \longrightarrow \mathbb{C}[x^{\pm 1}, y^{\pm 1}, z] \longrightarrow \mathbb{C}[x^{\pm 1}, y^{\pm 1}, z]^{\otimes 2} \longrightarrow \dots$$

where the first differential is multiplication by $1 - xy^{-1}$, and the second differential is given by $d(f) = f \otimes 1 + xy^{-1} \otimes f + \Delta(f)$. The kernel of it is generated by $1 - xy^{-1}$ and $y^{-1}z$, the latter being a representative for the nontrivial first Ext.

2.7 Tensor products and multibraces

One can see that the data of multiplication in A does not come up in the answer so far. This however suggests that \mathfrak{A} is equipped with additional structure. We notice that a *commutative* DG-algebra is a *monoidal* DG-category with one object, and while the passage to homotopy limit might not preserve this structure, at least something can be expected to survive. Indeed, in [ACD] the authors construct the monoidal structure on the homotopy category of all representations up to homotopy, which in particular restricts to the subcategory of characters. We obtain a similar answer for noncommutative DG-Hopf algebras as well.

Let $a = \{a_i\}$ and $b = \{b_i\}$ be two homotopy characters. Then a_1 and b_1 are homotopy invertible and homotopy grouplike, and so is $a_1 b_1$. Indeed, if $a_1 \otimes a_1 - \Delta(a_1) = d(a_2)$ and $b_1 \otimes b_1 - \Delta(b_1) = d(b_2)$, then

$$\begin{aligned}
& a_1 b_1 \otimes a_1 b_1 - \Delta(a_1 b_1) \\
&= (a_1 \otimes a_1)(b_1 \otimes b_1) - \Delta(a_1)\Delta(b_1) \\
&= (\Delta(a_1) + d(a_2))(\Delta(b_1) + d(b_2)) - \Delta(a_1)\Delta(b_1) \\
&= (\Delta(a_1) + d(a_2))d(b_2) + d(a_2)\Delta(b_1) \\
&= (a_1 \otimes a_1)d(b_2) + d(a_2)\Delta(b_1) \\
&= d((a_1 \otimes a_1)b_2 + a_2\Delta(b_1)).
\end{aligned}$$

We notice that $(a_1 b_1, (a_1 \otimes a_1)b_2 + a_2\Delta(b_1), \dots)$ starts looking like the beginning of another homotopy character. There is an asymmetry between a and b , but there is a certain freedom to modify the formulas above, so we could have also obtained $(a_1 b_1, a_2(b_1 \otimes b_1) + \Delta(a_1)b_2, \dots)$.

Theorem 2.7.1. Let $a = (a_1, a_2, \dots)$ and $b = (b_1, b_2, \dots)$ be homotopy characters. Then there exists a homotopy character $a \otimes b$, given by the formulas

$$(a \otimes b)_n = \sum_{i_1 + \dots + i_k = n} (a_{i_1} \otimes \dots \otimes a_{i_k})(\Delta^{i_1-1} \otimes \dots \otimes \Delta^{i_k-1})(b_n). \quad (2.14)$$

There also exists a homotopy character given by the formulas

$$(a \otimes b)_n = \sum_{i_1 + \dots + i_k = n} (\Delta^{i_1-1} \otimes \dots \otimes \Delta^{i_k-1})(a_n)(b_{i_1} \otimes \dots \otimes b_{i_k}) \quad (2.15)$$

Both tensor products of objects are strictly associative.

Proof. It can be explicitly checked that the Maurer-Cartan equation holds in both cases. Strict associativity of these tensor products is obtained by a direct computation. \square

The formulas above are the same as in Corollary 5.10 in [ACD] – in their notation, these are ω_0 and ω_1 . Theorem 5.6 in [ACD] states that the two different tensor products are actually homotopy equivalent.

The formulas (2.14) and (2.15) have an interpretation in terms of Kadeishvili's multibraces that exist on the Cobar-construction of a bialgebra and assemble into homotopy Gerstenhaber algebra structure. Recall the following definitions.

Definition 2.7.2. For a DG-algebra B with multiplication μ , its Bar-construction is, as a graded vector space,

$$\text{Bar}(B) = T(B[1]) = \bigoplus_{i=0}^{\infty} B[1]^{\otimes i}.$$

The comultiplication is that of a tensor coalgebra. The differential is given by $d = d_B + \mu$ into the cogenerators and extends to the rest of the coalgebra by coLeinbiz rule.

Definition 2.7.3. A DG-algebra B is a homotopy Gerstenhaber algebra (hGa) if it is equipped with a family of operations (multibraces)

$$E_{1,k}: B \otimes B^{\otimes k} \rightarrow B$$

that induce a associative multiplication on $\text{Bar}(B)$ consistent with its tensor comultiplication.

Remark 2.7.4. A multiplication on $\text{Bar}(B)$ is a coalgebra map

$$E: \text{Bar}(B) \otimes \text{Bar}(B) \rightarrow \text{Bar}(B).$$

As a coalgebra map, it is uniquely determined by its part that lands into the cogenerators, B . Denote its component $B^{\otimes l} \otimes B^{\otimes k} \rightarrow B$ by $E_{l,k}$. A family of $E_{l,k}$ that gives rise to an associative multiplication is known as Hirsch algebra structure on B . In Definition 2.7.3 we restrict ourselves to families where $E_{l,k}$ vanish when $l \neq 1$.

For elements b and b_1, \dots, b_k we write $E_{1,k}(b; b_1, \dots, b_k) = b\{b_1, \dots, b_k\}$ (thus the term multibraces). We can naturally modify the definitions above to also obtain operations $E_{k,1}$, for which we will write $E_{1,k}(b_1, \dots, b_k; b) = \{b_1, \dots, b_k\}b$. Let us call operations $E_{1,k}$ left multibraces, and operations $E_{k,1}$ right multibraces.

In Section 5 of [Ka] the author constructs (left) hGa structure on $B = \text{Cobar}(A)$ for a bialgebra A . For tensors $x = x^{(1)} \otimes \dots \otimes x^{(n)} \in B$ and $y_1, y_2, \dots, y_k \in B$, the left multibrace $E_{1,k}$ is given by

$$E_{1,k}(x; y_1, \dots, y_k) = \sum_{1 \leq i_1 < \dots < i_k \leq n} \pm x^{(1)} \otimes \dots \otimes (\Delta^{|y_1|-1}(x^{(i_1)}) \cdot y_1) \otimes \dots \otimes x^{(n)}.$$

By $|y|$ we mean the length of the tensor, and if $|x| = n < k$ then the multibrace vanishes.

One can similarly define the (right) hGa structure on the same B . For tensors $x_1, x_2, \dots, x_k \in B$ and $y = y^1 \otimes \dots \otimes y^{(n)} \in B$, the right multibrace $E_{k,1}$ is given by

$$E_{k,1}(x_1, \dots, x_n; y) = \sum_{1 \leq i_1 < \dots < i_k \leq n} \pm y^{(1)} \otimes \dots \otimes (x_1 \cdot \Delta^{|x_1|-1}(y^{(i_1)})) \otimes \dots \otimes y^{(n)}.$$

Now the formula (2.14) can be rewritten as

$$(a \otimes b)_n = \sum_{i_1 + \dots + i_k = n} \{a_{i_1}, \dots, a_{i_k}\} b_k$$

and the formula (2.15) can be rewritten as

$$(a \otimes b)_n = \sum_{i_1 + \dots + i_k = n} a_k \{b_{i_1}, \dots, b_{i_k}\}$$

Remark 2.7.5. The results of [ACD] on tensoring morphisms also work in our generality of non-commutative DG-Hopf algebra. However, extracted from its natural (operadic) framework, the formula looks totally unenlightening:

$$\begin{aligned} (f \otimes g)_n &= \\ &= \sum_{\substack{i_1 + \dots + i_k = n \\ 1 \leq m \leq k}} g_0(a_{i_1} \otimes \dots \otimes a_{i_{m-1}} \otimes f_{i_m} \otimes x_{i_{m+1}} \otimes \dots \otimes x_{i_k}) (\Delta^{i_1-1} \otimes \dots \otimes \Delta^{i_k-1}) b_k \\ &+ \sum_{i_1 + \dots + i_k = n} f_0(x_{i_1} \otimes \dots \otimes x_{i_k}) (\Delta^{i_1-1} \otimes \dots \otimes \Delta^{i_k-1}) g_k \\ &+ \sum_{\substack{i+j=n \\ i_1 + \dots + i_k = i \\ j_1 + \dots + j_l = j \\ 1 \leq m \leq k}} (a_{i_1} \otimes \dots \otimes a_{i_{m-1}} \otimes f_{i_m} \otimes x_{i_{m+1}} \otimes \dots \otimes x_{i_k} \otimes x_{j_1} \otimes \dots \otimes x_{j_l}) \\ &(\Delta^{i_1-1} \otimes \dots \otimes \Delta^{i_k-1}) b_k \otimes (\Delta^{j_1-1} \otimes \dots \otimes \Delta^{j_l-1}) g_l. \end{aligned}$$

We do not spell out the signs here, since the formula is already sufficiently intimidating in their absence. The tensor product of morphisms given by this formula is associative up to homotopy, and respects compositions up to homotopy. Packaging the data of all these higher homotopies is the goal of our ongoing project.

2.A Homotopy limit in DG-algebras

For any combinatorial model category \mathbf{C} and a diagram X of the shape Δ (the simplex category), one can use Bousfeld-Kan formula to find the homotopy limit as the *fat* totalization, see Example 6.4 in [AØ1]:

$$\mathrm{holim}_{\Delta} X = \int_{\Delta^+} R(X^n)_n$$

where R is some functor $\mathbf{C} \rightarrow \mathbf{C}^{\Delta^{opp}}$ which sends an object $c \in \mathbf{C}$ to its simplicial resolution, i.e. a Reedy-fibrant replacement of the constant simplicial diagram with value c .

We first present functorial simplicial resolutions for $\mathbf{C} \simeq \mathbf{DGVect}(\mathbf{k})$, and then extend the construction to $\mathbf{C} \simeq \mathbf{DGalg}(\mathbf{k})$. We then apply the fat totalization formula to compute the homotopy limit of a cosimplicial system associated with a DG-bialgebra.

2.A.1 Simplicial resolutions in $\mathbf{DGVect}(\mathbf{k})$

Let us present functorial simplicial resolutions for $\mathbf{DGVect}(\mathbf{k})$.

Recall a simplicial vector space X_\bullet is under Dold-Kan correspondence sent to its Moore complex $N(X)^\bullet$, given by $N(X)^{-n} = X_n/D_n$, where D_n is the degenerate part of X_n . The differential is the alternating sum of faces.

For $n \geq 0$, let $\mathbf{k}\Delta[n]$ be the linearization of the standard simplex, and set $L^n = N(\mathbf{k}\Delta[n])$. Explicitly, this complex is spanned by elements $f_{i_0 < \dots < i_k}$ of degree $-k$ for $k \geq 0$, with $i_0 \geq 0$ and $i_k \leq n$ – these are the nondegenerate simplices of $\Delta[n]$ that correspond to faces with vertices i_0, \dots, i_k . The differential in this basis is

$$d(f_{i_0 < \dots < i_k}) = \sum_{j=0}^k (-1)^j f_{i_0 < \dots < \widehat{i_j} < \dots < i_k}$$

where $\widehat{i_j}$ denotes dropping this index. Due to functoriality of N , L^\bullet is a cosimplicial system of complexes. For a map $\phi: [n] \rightarrow [m]$ in Δ , the corresponding map $\phi_*: L^n \rightarrow L^m$ is given by

$$\phi_*(f_{i_0 < \dots < i_k}) = \begin{cases} f_{\phi(i_0) < \dots < \phi(i_k)} & \text{if } \phi|_{\{i_0, \dots, i_k\}} \text{ is injective} \\ 0 & \text{otherwise} \end{cases}$$

Proposition 2.A.1. For $X \in \mathbf{DGVect}(\mathbf{k})$, the simplicial system $X^{[-]}$ gives a simplicial resolution of X , i.e. it is Reedy-fibrant, and there exists a map $\text{const}(X) \rightarrow X^{[-]}$ that is a levelwise quasiisomorphism.

Proof. The map $r: X \rightarrow X^{[n]}$ is given by $x \mapsto r(x)$ where $r(x)(f_i) = x$ for all i , and $r(x)(f_{i_0 < \dots < i_k}) = 0$ when $k > 0$. This respects differentials: we have

$$r(d_X(x))(f_i) = d_X(x) = d_X(r(x)(f_i)) - r(x)(d_{L^n}(f_i)) = d_{X^{[n]}}(r(x))(f_i)$$

and

$$(d_X(x))(f_{i < j}) = 0 = d_X(0) - r(x)(f_i - f_j) = d_{X^{[n]}}(r(x))(f_{i-j})$$

and for $k > 1$

$$r(d_X(x))(f_{i_0 < \dots < i_k}) = 0 = d_{X^{[n]}}(r(x))(f_{i_0 < \dots < i_k})$$

because in $d(f_{i_0 < \dots < i_k})$ all summands have degree strictly less than 0, so $r(x)$ vanishes on them.

We check that r is a quasiisomorphism. We first check that it is injective on cohomology. Let $x \in X$ be a closed element such that its image vanishes in cohomology, $r(x) = d_{X^{[n]}}(s)$ for some $s: L^n \rightarrow X$. Then

$$x = r(x)(f_0) = d_{X^{[n]}}(s)(f_0) = d_X(s(f_0)) - s(d_L(f_0))$$

so $x = d_X(s(f_0))$, i.e. it vanishes in cohomology.

We now check r is surjective on cohomology. Let $s: L^n \rightarrow X$ be a closed morphism. Then $r(s(f_0)) - s = d_{X^{[n]}}(t)$, where

$$t(f_0) = 0$$

$$t(f_i) = s(f_{0 < i}) \text{ if } i > 0$$

and in general,

$$t(f_{i_0 < \dots < i_k}) = \begin{cases} s(f_{0 < i_0 < \dots < i_k}) & \text{if } i_0 > 0 \\ 0 & \text{if } i_0 = 0 \end{cases}$$

For different n , these maps $r^{(n)}$ are consistent with cosimplicial structure: for $\phi: [m] \rightarrow [n]$ we have

$$r^{(m)}(x)(f_{i_0 < \dots < i_k}) = \begin{cases} x & k = 0 \\ 0 & k > 0 \end{cases}$$

and

$$\phi^*(r^{(n)}(x))(f_{i_0 < \dots < i_k}) = r^{(n)}(x)(\phi_*(f_{i_0 < \dots < i_k})) = \begin{cases} x & k = 0 \\ 0 & k > 0 \end{cases}$$

We are left to verify Reedy fibrancy, i.e. that matching maps are fibrations in $\text{DGVect}(\mathbf{k})$, i.e. surjections. By definition, the n^{th} matching object M_n is

$$M_n = \lim_{\delta([n] \downarrow (\Delta^{\text{op}})_-)} X^{[-]} = \lim_{[m] \hookrightarrow [n]} X^{[m]}.$$

These are morphisms from a subcomplex of $\bar{L}^n \subset L^n$ that is spanned by everything except $f_{0 < \dots < n}$. The matching map $m^n: X^{[n]} \rightarrow M_n$ is given by forgetting the value of a morphism $L^n \rightarrow X$ on $f_{0 < \dots < n}$. This is a surjection of chain complexes, as any morphism $\bar{L}^n \rightarrow X$ can be extended to a morphism $L^n \rightarrow X$ by assigning any value to $f_{0 < \dots < n}$. \square

2.A.2 Simplicial resolutions in $\text{DGA}(\mathbf{k})$

We now enhance our construction of simplicial resolutions from $\text{DGVect}(\mathbf{k})$ to $\text{DGA}(\mathbf{k})$. The result is motivated by Holstein resolutions in $\text{DGCat}(\mathbf{k})$ (see [Hol], [AP]) but simpler.

Proposition 2.A.2. The cosimplicial system of complexes L^\bullet can be upgraded to a cosimplicial system of DG-coalgebras, by introducing the following comultiplication:

$$\Delta(f_{i_0 < \dots < i_k}) = \sum_{j=0}^k f_{i_0 < \dots < i_j} \otimes f_{i_j < \dots < i_k}$$

Proof. Compatibility with differentials and with cosimplicial structure is checked by an elementary explicit computation. \square

Remark 2.A.3. Conceptually this is the comultiplication in standard simplices that is responsible for the existence of cup-product in singular cohomology.

Now, for any monoidal DG-category \mathbf{C} , if X is a coalgebra in \mathbf{C} and Y is an algebra in \mathbf{C} , then the complex $\mathbf{C}(X, Y)$ is a DG-algebra by means of convolution:

$$\mathbf{C}(X, Y) \otimes \mathbf{C}(X, Y) \simeq \mathbf{C}(X \otimes X, Y \otimes Y) \xrightarrow{(\Delta_X, \mu_Y)} \mathbf{C}(X, Y)$$

We are working in the case when \mathbf{C} is the category of chain complexes, $\text{DGVect}(\mathbf{k})$. Coalgebras in $\text{DGVect}(\mathbf{k})$ are DG-coalgebras and algebras in $\text{DGVect}(\mathbf{k})$ are DG-algebras. So for A a DG-algebra, the Hom-complex $\text{Hom}^\bullet(L^n, A)$ has a DG-algebra structure. Denote this algebra by $A^{[n]}$.

Proposition 2.A.4. For a DG-algebra A , the simplicial system $A^{[-]}$ gives a simplicial resolution of A , i.e. it is Reedy-fibrant, and there exists a map $\text{const}(A) \rightarrow A^{[-]}$ that is a levelwise quasiisomorphism.

Proof. The map $r: A \rightarrow A^{[n]}$ is exactly the same as in the case of $\text{DGVect}(\mathbf{k})$ - namely, $a \mapsto r(a)$ where $r(a)(f_i) = a$ for all i , and $r(a)(f_{i_0 < \dots < i_k}) = 0$ when $k > 0$. We check that this map is compatible with multiplication:

$$(r(a) * r(b))(f_i) = \mu_A(r(a) \otimes r(b))(f_i \otimes f_i) = ab = r(ab)(f_i).$$

and for $k > 0$

$$(r(a) * r(b))(f_{i_0 < \dots < i_k}) = 0 = r(ab)(f_{i_0 < \dots < i_k})$$

because in every summand of $\Delta(f_{i_0 < \dots < i_k})$ at least one of the components has degree strictly less than 0.

It was already verified in the proof of Proposition 2.A.1 that r is compatible with differentials and is a quasiisomorphism.

In checking Reedy fibrancy we are left to notice that the subcomplex $\bar{L}^n \subset L^n$ (spanned by all basis elements except for $f_{0<\dots<n}$) is actually a subcoalgebra, so matching objects and matching maps in $\text{DGA}(\mathbf{k})$ are the same as in $\text{DGVect}(\mathbf{k})$. \square

2.A.3 Fat totalizations in $\text{DGVect}(\mathbf{k})$ and $\text{DGA}(\mathbf{k})$

Let X^\bullet be the cosimplicial complex in whose homotopy limit we are interested. Then

$$\text{holim}_\Delta X^\bullet = \int_{\Delta^+} (X^n)^{[n]} = \text{Eq} \left(\prod_{n \geq 0} \text{Hom}^\bullet(L^n, X^n) \rightrightarrows \prod_{[m] \hookrightarrow [n]} \text{Hom}^\bullet(L^m, X^n) \right).$$

This is the complex $\text{Nat}_{\Delta^+}(L^\bullet, X^\bullet)$ of natural transformations between two functors $\Delta^+ \rightarrow \text{DGVect}(\mathbf{k})$.

Proposition 2.A.5. As a graded vector space, the homotopy limit of a cosimplicial vector space X^\bullet is given by

$$\text{holim}_\Delta X^\bullet = \prod_{n=0}^{\infty} X^n[-n].$$

For an element $x = (x_0, x_1, \dots)$, its differential is given by

$$d(x)_n = d_{X^n}(x_n) - \sum_{i=0}^n \partial^{(0 \dots \hat{i} \dots n)}(x_{n-1}). \quad (2.16)$$

Proof. A natural transformation $\phi: L^\bullet \rightarrow X^\bullet$ consists of maps $\phi^n: L^n \rightarrow X^n$ for all n . For all indexing subsets I smaller than $\{0 < \dots < n\}$, the generator f_I is in the image of $i^*: L^m \rightarrow L^n$ for some $i: [m] \hookrightarrow [n] \in \Delta^+$, $m < n$. Thus the only part of ϕ^n that is not determined by ϕ^m for $m < n$ is its value $\phi^n(f_{0<\dots<n})$. So the graded isomorphism

$$\text{Nat}_{\Delta^+} \xrightarrow{\cong} \prod_{n=0}^{\infty} X^n[-n]$$

is given by $\phi \mapsto \phi^0(f_0) \times \phi^1(f_{0<1}) \times \phi^2(f_{0<1<2}) \dots = (\phi^n(f_{0<\dots<n}))_{n=0}^\infty$.

The differential comes from the differential in $\prod_{n \geq 0} \text{Hom}^\bullet(L^n, X^n)$. Let $x = (x_0, x_1, \dots)$ be an element with the corresponding natural transformation $\phi = (\phi^0, \phi^1, \dots)$ with $\phi^n(f_{0<\dots<n}) = x_n$. Then we have

$$\begin{aligned} d_{\text{Hom}}(\phi^n)(f_{0<\dots<n}) &= d_{X^n}(\phi^n(f_{0<\dots<n})) - \phi^n(d_{L^n}(f_{0<\dots<n})) \\ &= d_{X^n}(x_n) - \sum_{i=0}^n \partial^{(0 \dots \hat{i} \dots n)}(x_{n-1}) \end{aligned}$$

□

Now let A^\bullet be the cosimplicial DG-algebra in whose homotopy limit we are interested.

Proposition 2.A.6. The underlying complex of $\text{holim}_\Delta(A^\bullet)$ is as described in Proposition 2.A.5. For two elements $a = (a_0, a_1, \dots)$ and $b = (b_0, b_1, \dots)$, their product is given by

$$(a \cdot b)_n = \sum_{i=0}^n \partial^{(0\dots i)}(a_i) \cdot \partial^{(i\dots n)}(b_{n-i}) \quad (2.17)$$

Proof. The description of the underlying complex follows from the fact that simplicial resolutions in $\text{DGVect}(\mathbf{k})$ are the underlying complexes of simplicial resolutions in $\text{DGA}(\mathbf{k})$. We now recover the multiplication given by convolution. Let ϕ and ψ be two natural transformations corresponding to $a = (a_0, a_1, \dots)$ and $b = (b_0, b_1, \dots)$. Then

$$\begin{aligned} (\phi * \psi)^n(f_{0<\dots<n}) &= (\phi^n * \psi^n)(f_{0<\dots<n}) = \mu_{A^n}(\phi^n \otimes \psi^n)\Delta_{L^n}(f_{0<\dots<n}) \\ &= \mu_{A^n}(\phi^n \otimes \psi^n) \left(\sum_{i=0}^n f_{0<\dots<i} \otimes f_{i<\dots<n} \right) = \sum_{i=0}^n \phi^n(f_{0<\dots<i}) \cdots \psi^n(f_{i<\dots<n}) \\ &= \sum_{i=0}^n \partial^{(0\dots i)}(\phi^i(f_{0<\dots<i})) \cdot \partial^{(i\dots n)}(\psi^{n-i}(f_{0<\dots<n-i})) \\ &= \sum_{i=0}^n \partial^{(0\dots i)}(a_i) \cdot \partial^{(i\dots n)}(b_{n-i}) \end{aligned}$$

□

2.A.4 Application to the cosimplicial system of a DG-bialgebra

Let A be a DG-bialgebra, and let A^\bullet be its associated cosimplicial system of DG-algebras, as in (2.1). Let us use the above formulas to compute its homotopy limit.

Proposition 2.A.7. $\text{holim}_\Delta(A^\bullet) \simeq \text{Cobar}_{\text{coaug}}(A)$.

Proof. By Proposition 2.A.5, the underlying graded vector space of the homotopy limit is $\prod_{i=0}^n A^{\otimes i}$, which is exactly the underlying graded vector space of $\text{Cobar}_{\text{coaug}}(A)$. With the data of appropriate faces, the formula (2.16) translates into the differential of the reduced Cobar construction, and the formula (2.17) translates into tensor multiplication. □

Bibliography

- [AC] C.A. Abad, M. Crainic. "Representations up to homotopy and Bott's spectral sequence for Lie groupoids"
- [ACD] C.A. Abad, M. Crainic, B. Dherin. "Tensor products of representations up to homotopy".
- [AØ1] S. Arkhipov, S. Ørsted. "Homotopy (co)limits via homotopy (co)ends in general combinatorial model categories". ArXiv preprint 1807.03266, (2018).
- [AØ2] S. Arkhipov, S. Ørsted. "Homotopy limits in the category of dg-categories in terms A_∞ comodules". ArXiv preprint 1812.03583, (2018).
- [AP] S. Arkhipov, D. Poliakova. "A note on a Holstein construction". Homology, Homotopy and Applications, 22(2) (2020), pp. 151-162.
- [BHW] J. Block, J. V. Holstein, and Z. Wei. "Explicit homotopy limits of dg categories and twisted complexes". Homology, Homotopy and Applications, 19(2) (2017), pp. 343-371.
- [Hov] M. Hovey, "Model categories"
- [Hol] J. Holstein. "Properness and simplicial resolutions for the model category dgCat "
- [Hir] P.S. Hirschhorn. "Model Categories and Their Localizations".
- [Ka] T. Kadeishvili, On the cobar construction of a bialgebra, Homology Homotopy Appl. 7 (2005), no. 2, 109-122
- [Kel] B. Keller, "Introduction to A-infinity algebras and modules". Homology, Homotopy and Applications, 3(1) (2001), 1-35.
- [Pos] L. Positselski, "Two Kinds of Derived Categories, Koszul Duality, and Comodule-Contramodule Correspondence". Memoirs of the American Mathematical Society.
- [Tab] G. Tabuada. "Une structure de categorie de modeles de Quillen sur la categorie des dg-categories"

Chapter 3

Cellular chains on freehedra and operadic pairs

3.1 Introduction

The present paper grew out of the author's attempts to understand and extend the constructions of [ACD].

In [AC], representations up to homotopy of a derived algebraic group G were introduced as A_∞ -comodules over the group coalgebra $A := \mathcal{O}(G)$. They form a DG-category $\text{Rep}^h(G)$. In [ACD] it was proved that the homotopy category of $\text{Rep}^h(G)$ is monoidal.

To construct tensor products, the authors used the language of DB-algebras and DB-bimodules (see section 3.2 and 6.1 in [ACD]) and studied the algebra of $\text{Rep}^h(G)$ by means of a certain universal DB-pair (Ω, T) . The tensor product of objects in $\text{Rep}^h(G)$ was given by a diagonal $\Omega \rightarrow \Omega \boxtimes \Omega$, and the tensor product of morphisms was given by a diagonal $T \rightarrow T \boxtimes T$. The resulting tensor product of morphisms was only homotopy associative and homotopy consistent with compositions. It was left as an open question whether this monoidal structure admits some sort of a coherent lift to DG-level.

In operadic language, the DB-algebra Ω corresponds to an (\mathbf{a}, \mathbf{m}) -colored operad Ω governing pairs of a DG-algebra and an A_∞ -module over it. The DB-bimodule T corresponds to an operadic Ω -bimodule T governing maps of such pairs which are homomorphisms in color \mathbf{a} and A_∞ in color \mathbf{m} . We axiomatize the situation by defining *operadic pairs* and algebras over them. The pair (Ω, T) provides an example of an operadic pair.

The context for operadic pairs is as follows. The category of A_∞ -algebras

is *not* the category of algebras over the DG-operad A_∞ , because the latter category does not have enough morphisms. However, there exists an operadic pair (A_∞, M_∞) , for which there is an equivalence of categories $A_\infty \text{ Alg} \simeq \text{Alg}(A_\infty, M_\infty)$. The operadic pair (A_∞, M_∞) consists of cellular chains on *Stasheff associahedra* and *Stasheff multiplihedra*. The same holds for its (\mathbf{a}, \mathbf{m}) -colored version $(A_\infty^{\text{Col}}, M_\infty^{\text{Col}})$. Algebras over $(A_\infty^{\text{Col}}, M_\infty^{\text{Col}})$ are pairs of an A_∞ -algebra and an A_∞ -module over it, and maps of such pairs are A_∞ in both colors. The operadic pair (Ω, T) above is a certain quotient of $(A_\infty^{\text{Col}}, M_\infty^{\text{Col}})$.

On the polyhedral side, taking quotients corresponds to contraction. The contraction of associahedra corresponding to the projection $A_\infty^{\text{Col}} \rightarrow \Omega$ was known from [ACD]; it resulted in *cubes*. For the projection $M_\infty^{\text{Col}} \rightarrow T$, the corresponding contraction was not previously known. In this paper we compute it and prove the following:

Theorem. There exists an isomorphism of chain complexes $C_*(\mathcal{F}_n) \simeq T(\mathbf{a}^n, \mathbf{m}; \mathbf{m})$, where \mathcal{F}_n are freehedra of [San].

These polytopes were originally introduced to study free loop spaces, and until now they bore no relation to operads. Therefore, the current paper establishes a dictionary between [San] and [ACD]. In particular, it seems that the freehedral diagonal of [San] coincides with the diagonal $T \rightarrow T \boxtimes T$ of [ACD]. In further research we expect to use polyhedral methods to define *weakly Hopf* structure on the operadic pair (Ω, T) . This would provide a weakly monoidal structure on the DG-category $\text{Rep}^h(G)$, giving a lift from the homotopy level.

3.1.1 Organization of the paper

This paper aims to be as self-contained as possible, thus the length. In Section 2 we give an overview of operadic theory in one and two colors, and introduce operadic pairs. In Section 3 we present associahedra and multiplihedra. In section 4 we summarize the existing definitions of freehedra. In Section 5 we prove our main theorem, which provides an operadic meaning for freehedra. In Section 6 we discuss the existing projections between polyhedral families in terms of operadic pairs. In Section 7 we define strictly Hopf operadic pairs and prepare the ground for studying weakly Hopf operadic pairs.

3.1.2 Acknowledgements

This paper would not have been written without Jim Stasheff's advice and support. I am also grateful to Sergey Arkhipov, Ryszard Nest, Lars Hessel-

holt, Nathalie Wahl, Camilo Abad, Stephen Forcey and Samson Sanedlidze for discussions and interest. Finally, I am grateful to Vladimir Dotsenko, Timothy Logvinenko and Svetlana Makarova for inviting me to present this research at their seminars.

3.2 Operads and operadic pairs

Let \mathbf{C} be a closed monoidal category with sums.

Definition 3.2.1. In the category $\mathbb{N}\text{-Seq}(\mathbf{C})$ of \mathbb{N} -sequences in \mathbf{C} , an object \mathcal{P} is a collection of $\mathcal{P}(i) \in \mathbf{C}$ for $i \geq 1$. For \mathcal{P} and \mathcal{Q} in $\mathbb{N}\text{-Seq}(\mathbf{C})$, their tensor-product $\mathcal{P} \odot \mathcal{Q}$ is given by

$$(\mathcal{P} \odot \mathcal{Q})(n) = \bigoplus_{i_1 + \dots + i_k = n} \mathcal{P}(k) \otimes \mathcal{Q}(i_1) \otimes \dots \otimes \mathcal{Q}(i_k)$$

This makes $\mathbb{N}\text{-Seq}(\mathbf{C})$ a non-symmetric monoidal category. The unit is the \mathbb{N} -sequence \mathbb{I} with $\mathbb{I} = \mathbb{I}$ and $\mathbb{I}(n) = 0$ for $n \geq 1$, where \mathbb{I} is the monoidal unit of \mathbf{C} and 0 is the initial object of \mathbf{C} .

Definition 3.2.2. An non-symmetric operad in \mathbf{C} is a unital algebra in $\mathbb{N}\text{-Seq}(\mathbf{C})$.

If \mathcal{P} is an operad, we say that $\mathcal{P}(k)$ is the object of arity k operations. Explicitly, the operadic structure on \mathcal{P} is given by a collection of composition maps

$$\circ_{i_1, \dots, i_k} : \mathcal{P}(k) \otimes \mathcal{P}(i_1) \otimes \dots \otimes \mathcal{P}(i_k) \rightarrow \mathcal{P}(i_1 + \dots + i_k)$$

satisfying associativity conditions. The existence of a unit allows us to express all such compositions through

$$\circ_i : \mathcal{P}(k) \otimes \mathcal{P}(l) \rightarrow \mathcal{P}(k + l - 1)$$

Definition 3.2.3. Every object $X \in \mathbf{C}$ gives rise to its operad $\underline{\text{End}}_X$, with $\underline{\text{End}}_X(n) = \underline{\text{Hom}}_{\mathbf{C}}(X^{\otimes n}, X)$ and with operadic structure coming from compositions.

Definition 3.2.4. For an operad \mathcal{P} and an object X , the structure of a \mathcal{P} -algebra on X is a map of operads $\mathcal{P} \rightarrow \underline{\text{End}}_X$. If X and Y are \mathcal{P} -algebras, their *map in* $\text{Alg}(\mathcal{P})$ is a map $X \rightarrow Y$ such that for any n the diagram below commutes:

$$\begin{array}{ccc} \mathcal{P}(n) \otimes X^{\otimes n} & \xrightarrow{\text{id}_{\mathcal{P}(n)} \otimes f^{\otimes n}} & \mathcal{P}(n) \otimes Y^{\otimes n} \\ \downarrow & & \downarrow \\ X & \xrightarrow{f} & Y \end{array}$$

Let \mathbf{C} be the category of chain complexes $\text{DGVect}(\mathbf{k})$. Operads in $\text{DGVect}(\mathbf{k})$ are called DG-operads. The simplest DG-operad is Ass , with $Ass(n) = k$ for any n . Algebras over Ass are DG algebras. The key operad for this paper is a classical resolution of Ass called A_∞ . For detailed discussion of A_∞ -formalism, see for example [Kel].

Definition 3.2.5. The DG-operad A_∞ is generated by operations μ_n of arity n and degree $2 - n$ for $n \geq 2$, with differential

$$d(\mu_n) = \sum_{i+j+k=n} \mu_{i+1+k}(\text{id}^{\otimes i} \otimes \mu_j \otimes \text{id}^{\otimes k})$$

A_∞ -algebras are homotopy-associative algebras with an explicit system of all the higher coherences.

Remark 3.2.6. The category of algebras over A_∞ is *not* what people usually mean by the category of A_∞ -algebras. The problem is that $\text{Alg}(A_\infty)$ doesn't have enough morphisms. A morphism $A \rightarrow B$ in $\text{Alg}(A_\infty)$ has to strictly respect multiplication μ_2 and all the higher operations. A true A_∞ -morphism $A \rightarrow B$ should respect multiplication μ_2 only up to homotopy, and includes the data of all the higher coherences $A^{\otimes n} \xrightarrow{\text{deg } 1-n} B$.

To combat this difficulty we use operadic bimodules, i.e. bimodules in the category $\mathbf{N}\text{-Seq}(\mathbf{C})$. Note that this is not a symmetric monoidal category, so left and right actions differ a lot.

Definition 3.2.7. For objects $X, Y \in \mathbf{C}$, let $\underline{\text{Hom}}_{X,Y}$ be an \mathbf{N} -sequence given by $\underline{\text{Hom}}_{X,Y}(n) = \underline{\text{Hom}}_{\mathbf{C}}(X^{\otimes n}, Y)$. It has a natural structure of a right module over $\underline{\text{End}}_X$ and of a left module over $\underline{\text{End}}_Y$ given by compositions.

Below we present the standard resolution of the trivial Ass -bimodule given by Ass itself.

Definition 3.2.8. M_∞ is a bimodule over A_∞ generated by f_n of arity n and degree $1 - n$ for $n \geq 0$, with differentials

$$d(f_n) = \sum f_{r+1+t}(\text{id}^{\otimes r} \otimes \mu_s \otimes \text{id}^{\otimes t}) + \sum \mu_r(f_{i_1} \otimes \dots \otimes f_{i_r})$$

Proposition 3.2.9. Let A, B be two A_∞ -algebras with structure maps $\alpha: A_\infty \rightarrow \underline{\text{End}}_A$ and $\beta: A_\infty \rightarrow \underline{\text{End}}_B$. Then any A_∞ -morphism $f: A \rightarrow B$ is given by a structure map $\phi: M_\infty \rightarrow \underline{\text{Hom}}_{X,Y}$ of bimodules over A_∞ , where $\underline{\text{Hom}}_{X,Y}$ is viewed as a bimodule over A_∞ via restrictions along α and β .

Note that the composition of A_∞ -morphisms is induced by a map

$$c: M_\infty \rightarrow M_\infty \otimes_{A_\infty} M_\infty$$

which is given on generators by

$$c(f_n) = \sum f_i \otimes f_{n-i+1}$$

and the identity A_∞ -morphisms are induced by a map

$$\epsilon: M_\infty \rightarrow A_\infty$$

which is given on generators by

$$\epsilon(f_n) = \begin{cases} \text{id} & n = 1 \\ 0 & n > 1 \end{cases}$$

This suggests the following new definition.

Definition 3.2.10. An *operadic pair* is a pair $(\mathcal{P}, \mathcal{M})$ where \mathcal{P} is an operad and \mathcal{M} is a counital coalgebra in operadic bimodules over \mathcal{P} , with comultiplication $c: \mathcal{M} \rightarrow \mathcal{M} \otimes_{\mathcal{P}} \mathcal{M}$ and counit $\epsilon: \mathcal{M} \rightarrow \mathcal{P}$.

Definition 3.2.11. For an operadic pair $(\mathcal{P}, \mathcal{M})$, an object of $\text{Alg}(\mathcal{P}, \mathcal{M})$ is just a \mathcal{P} -algebra. For two such objects A and B , with structure maps $\chi_A: \mathcal{P} \rightarrow \underline{\text{End}}_A$ and $\chi_B: \mathcal{P} \rightarrow \underline{\text{End}}_B$, a morphism f in $\text{Alg}(\mathcal{P}, \mathcal{M})$ is given by a structure map of \mathcal{P} -bimodules $\chi_f: \mathcal{M} \rightarrow \underline{\text{Hom}}_{A,B}$. The composition is induced by c and the identity morphisms are induced by ϵ .

Then (A_∞, M_∞) is an example of DG-operadic pair, and the category of A_∞ -algebras is precisely $\text{Alg}(A_\infty, M_\infty)$.

Remark 3.2.12. Every operad \mathcal{P} forms a counital coalgebra in bimodules over itself, resulting in a trivial operadic pair $(\mathcal{P}, \mathcal{P})$. For this pair, we have $\text{Alg}(\mathcal{P}, \mathcal{P}) = \text{Alg}(\mathcal{P})$.

For an operadic pair $(\mathcal{P}, \mathcal{M})$, by its underlying pair we mean the pair $(\mathcal{P}, \mathcal{M})$ with forgotten coalgebra structure on \mathcal{M} .

We now repeat the story with colors. Fix the set of colors Col .

Definition 3.2.13. In the category $\mathbb{N}\text{-Seq}_{\text{Col}}(\mathbb{C})$ of colored \mathbb{N} -sequences in \mathbb{C} , an object \mathcal{P} is a collection of $\mathcal{P}(c_1, \dots, c_k; c) \in \mathbb{C}$ for all tuples c_1, \dots, c_k, c with c_i and c in Col . Here, c_i are called input colors and c is called output color. For \mathcal{P} and \mathcal{Q} in $\mathbb{N}\text{-Seq}_{\text{Col}}(\mathbb{C})$, their tensor-product $\mathcal{P} \odot \mathcal{Q}$ is given by

$$(\mathcal{P} \odot \mathcal{Q})(c_1, \dots, c_n; c) = \bigoplus_{\substack{i_1 + \dots + i_k = n \\ c'_1, \dots, c'_k \in \text{Col}}} \mathcal{P}(c'_1, \dots, c'_k; c) \otimes \mathcal{Q}(c_1, \dots, c_{i_1}; c'_1) \otimes \dots \otimes \mathcal{Q}(c_{n-i_k+1}, \dots, c_n; c'_k)$$

Colored operads and colored operadic bimodules are defined as algebras and bimodules in this new monoidal category.

Definition 3.2.14. Let $\{X_c\}_{c \in \text{Col}}$ be a collection of objects in \mathbf{C} . The colored operad $\underline{\text{End}}_{\{X_c\}}$ is defined by

$$\underline{\text{End}}_{\{X_c\}}(c_1, \dots, c_n; c) = \underline{\text{Hom}}_{\mathbf{C}}(X_{c_1} \otimes \dots \otimes X_{c_n}, X_c)$$

with operadic structure given by compositions.

Definition 3.2.15. An algebra over a colored operad \mathcal{P} is a collection of objects $\{X_c\}_{c \in \text{Col}}$ with a map of operads $\mathcal{P} \rightarrow \underline{\text{End}}_{\{X_c\}}$. If $\{X_c\}$ and $\{Y_c\}$ are \mathcal{P} -algebras, then their map in $\text{Alg}(\mathcal{P})$ is a collection of maps $f_c: X_c \rightarrow Y_c$ such that for every tuple (c_1, \dots, c_n, c) the following diagram commutes.

$$\begin{array}{ccc} \mathcal{P}(c_1, \dots, c_n; c) \otimes \bigotimes_{i=1}^n X_{c_i} & \xrightarrow{\text{id} \otimes \bigotimes_{i=1}^n f_{c_i}} & \mathcal{P}(c_1, \dots, c_n; c) \otimes \bigotimes_{i=1}^n Y_{c_i} \\ \downarrow & & \downarrow \\ X_c & \xrightarrow{f_c} & Y_c \end{array}$$

Definition 3.2.16. Let $\{X_c\}_{c \in \text{Col}}$ and $\{Y_c\}_{c \in \text{Col}}$ be two collections of objects in \mathbf{C} . The colored \mathbb{N} -sequence $\underline{\text{Hom}}_{\{X_c\}, \{Y_c\}}$ is defined by

$$\underline{\text{Hom}}_{\{X_c\}, \{Y_c\}}(c_1, \dots, c_n; c) = \underline{\text{Hom}}_{\mathbf{C}}(X_{c_1} \otimes \dots \otimes X_{c_n}, Y_c)$$

It has the natural structure of a left module over $\underline{\text{End}}_{\{X_c\}}$ and a right module over $\underline{\text{End}}_{\{Y_c\}}$ given by compositions.

The definition of an operadic pair can now be repeated verbatim.

In the rest of the paper we will only be interested in the case when $\text{Col} = \{\mathbf{a}, \mathbf{m}\}$, with \mathbf{a} for *algebra* and \mathbf{m} for *module*. The simplest example of a colored DG-operad is Ass^{Col} , has $\text{Ass}^{\text{Col}}(\mathbf{a}, \dots, \mathbf{a}; \mathbf{a}) = k$, $\text{Ass}^{\text{Col}}(\mathbf{a}, \dots, \mathbf{a}, \mathbf{m}; \mathbf{m}) = k$ and 0 everywhere else. An algebra over this colored operad is a pair (A, M) where A is a DG-algebra and M is a DG-module over A . Similarly to the non-colored case, the operad Ass^{Col} has a standard resolution A_{∞}^{Col} .

Definition 3.2.17. A_{∞}^{Col} is generated by operations $\mu_n^{\mathbf{a}} \in A_{\infty}^{\text{Col}}(\mathbf{a}^n; \mathbf{a})$ of degree $2 - n$ and $\mu_n^{\mathbf{m}} \in A_{\infty}^{\text{Col}}(\mathbf{a}^{n-1}, \mathbf{m}; \mathbf{a})$ of degree $2 - n$, with differentials

$$\begin{aligned} d(\mu_n^{\mathbf{a}}) &= \sum_{i+j+k=n} \mu_{i+1+k}^{\mathbf{a}}(\text{id}_{\mathbf{a}}^{\otimes i} \otimes \mu_j^{\mathbf{a}} \otimes \text{id}_{\mathbf{a}}^{\otimes j}) \\ d(\mu_n^{\mathbf{m}}) &= \sum_{\substack{i+j+k=n \\ j \geq 1, k \geq 1}} \mu_{i+1+k}^{\mathbf{a}}(\text{id}_{\mathbf{a}}^{\otimes i} \otimes \mu_j^{\mathbf{a}} \otimes \text{id}_{\mathbf{m}}^{\otimes j}) + \sum_{\substack{i+j=n \\ j \geq 1}} \mu(\text{id}_{\mathbf{a}}^{\otimes i} \otimes \mu_j^{\mathbf{m}}) \end{aligned}$$

Again, the correct category of algebras is obtained via the formalism of operadic pairs.

Definition 3.2.18. The operadic bimodule M_∞^{Col} is generated over A_∞^{Col} by $f_n^{\mathbf{a}}$ and $f_n^{\mathbf{m}}$, with differentials

$$d(f_n^{\mathbf{a}}) = \sum f_{r+1+t}^{\mathbf{a}}(\text{id}_{\mathbf{a}}^{\otimes r} \otimes \mu_s^{\mathbf{a}} \otimes \text{id}_{\mathbf{a}}^{\otimes t}) + \sum \mu_r^{\mathbf{a}}(f_{i_1}^{\mathbf{a}} \otimes \dots \otimes f_{i_r}^{\mathbf{a}})$$

$$d(f_n^{\mathbf{m}}) = \sum f_{r+1+t}^{\mathbf{m}}(\text{id}_{\mathbf{a}}^{\otimes r} \otimes \mu_s^{\mathbf{a}} \otimes \text{id}_{\mathbf{m}}^{\otimes t}) + \sum \mu_r^{\mathbf{a}}(f_{i_1}^{\mathbf{a}} \otimes \dots \otimes f_{i_r}^{\mathbf{m}}) + \sum f_{r+1+t}^{\mathbf{m}}(\text{id}_{\mathbf{a}}^{\otimes r} \otimes \mu_t^{\mathbf{m}})$$

The comultiplication $c: M_\infty^{\text{Col}} \rightarrow M_\infty^{\text{Col}} \otimes_{A_\infty^{\text{Col}}} M_\infty^{\text{Col}}$ is given on generators by

$$c(f_n^{\mathbf{a}}) = \sum f_i^{\mathbf{a}} \otimes f_{n-i+1}^{\mathbf{a}}$$

$$c(f_n^{\mathbf{m}}) = \sum f_i^{\mathbf{m}} \otimes f_{n-i+1}^{\mathbf{m}}$$

The counit $\epsilon: M_\infty^{\text{Col}} \rightarrow A_\infty^{\text{Col}}$ is given on generators by

$$\epsilon(f_n^{\mathbf{a}}) = \begin{cases} \text{id}_{\mathbf{a}} & n = 1 \\ 0 & n > 1 \end{cases}$$

$$\epsilon(f_n^{\mathbf{m}}) = \begin{cases} \text{id}_{\mathbf{m}} & n = 1 \\ 0 & n > 1 \end{cases}$$

This makes $(A_\infty^{\text{Col}}, M_\infty^{\text{Col}})$ an operadic pair.

In this paper, we are interested mainly in a certain quotient of $(A_\infty^{\text{Col}}, M_\infty^{\text{Col}})$.

Definition 3.2.19. Let Ω be the quotient of A_∞^{Col} by the ideal I generated by all $\mu_i^{\mathbf{a}}$ for $i > 2$. Let T be a further quotient of M_∞^{Col}/I by a subbimodule generated by $f_i^{\mathbf{a}}$ for $i > 1$.

(Ω, T) remains an operadic pair.

Albeit in a different language, the operadic pair (Ω, T) was closely studied in [ACD] in connection to representations up to homotopy. There the authors developed a convenient forest notation for bases of Ω and T , which we use in the main theorem of this paper.

Definition 3.2.20. A *short forest* is a sequence of planar trees of depth 2. Inner edges are called branches and outer edges are called leaves. For a short forest F , let $l(F)$ be the number of leaves, let $b(F)$ be the number of branches and let $t(F)$ be the number of trees.

Below is an example of a short forest F with $l(F) = 12$, $b(F) = 8$ and $t(F) = 5$. The roots are depicted as connected with a horizontal line, the ground.

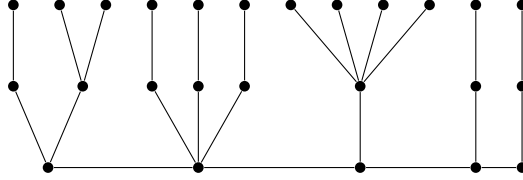

For a forest F , denote by F^i its i -th tree. Write F^i as $(F_1^i, \dots, F_{b_i}^i)$, where F_j^i denoted the number of leaves on the j -th branch of i -th tree.

Proposition 3.2.21. The basis of $\Omega(a^i, m; m)$ is given by short forests with $l(F) = i$, where the degree of the forest is $t(F) - b(F)$.

Proof. To the tree $F^i = (F_1^i, \dots, F_{b_i}^i)$ we assign the operation

$$\mu(F^i) = \mu_{b_i}^{\mathbf{m}} \left((\mu_2^{\mathbf{a}})^{F_1^i-1}, \dots, (\mu_2^{\mathbf{a}})^{F_{b_i}^i-1}, \text{id}^{\mathbf{m}} \right)$$

The powers of $\mu_2^{\mathbf{a}}$ are well-defined since $\mu_2^{\mathbf{a}}$ is associative. We then build the operation for the whole forest by composing $\mu(F^i)$ for all the trees in the same order as the trees appear in the forest. \square

Under this isomorphism, the example forest above corresponds to the operation

$$\mu_2^{\mathbf{m}} \left(\text{id}^{\mathbf{a}}, \mu_2^{\mathbf{a}}, \mu_3^{\mathbf{m}} \left(\text{id}^{\mathbf{a}}, \text{id}^{\mathbf{a}}, \text{id}^{\mathbf{a}}, \mu_1^{\mathbf{m}} \left((\mu_2^{\mathbf{a}})^3, \mu_1^{\mathbf{m}} (\text{id}^{\mathbf{a}}, \mu_1^{\mathbf{m}}) \right) \right) \right)$$

The differential of Ω in this basis can be described in terms of two forest transformations, U (for "unite") and S (for "separate"). Let F be a forest with a chosen pair of branches $B = (B_l, B_r)$ belonging to the same tree T .

1. $U(F, B)$ is the forest where B_l and B_r are replaced with the one branch that has leaves of both B_l and B_r .
2. $S(F, B)$ is the forest where T is replaced by two separate trees, T_l with branches of T up to B_l and T_r with branches of T starting from B_r .

For example, consider the following forest with $B = (B_l, B_r)$ highlighted green:

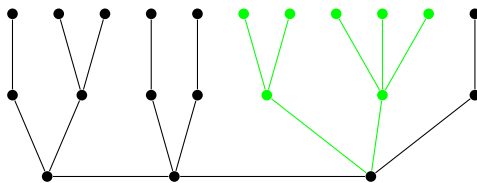

Then $U(F, B)$ and $S(F, B)$ are the two forests below.

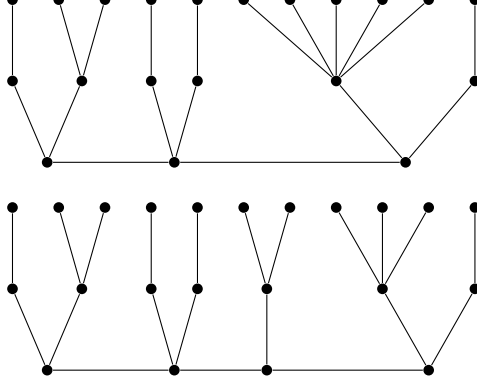

Proposition 3.2.22. Under the correspondence of Prop. 3.2.21, the differential of Ω is this:

$$d(F) = \sum_{B=(B_l, B_r)} \pm U(F, B) + \sum_{B=(B_l, B_r)} \pm S(F, B)$$

where in both sums B runs along the set of neighbouring branch pairs. The operadic composition is given by forest concatenation when composing two-colored operations or by leaf multiplication when composing with a one-colored operation.

We now explain a similar description for T .

Proposition 3.2.23. The basis of $T(\mathbf{a}^i, \mathbf{m}; \mathbf{m})$ is given by triples (F, T, G) where F and G are forests, T is a tree, and the total number of leaves is i .

Proof. To the tree $F^i = (F_1^i, \dots, F_{b_i}^i)$ in the left forest, we assign the operation

$$\mu(F^i) = \mu_{b_i}^{\mathbf{m}} \left((\mu_2^{\mathbf{a}})^{F_1^i - 1}, \dots, (\mu_2^{\mathbf{a}})^{F_{b_i}^i - 1}, \text{id}_{\mathbf{m}} \right)$$

To the middle tree $T = (T_1, \dots, T_t)$, we assign the operation

$$\mu(T) = f_t^{\mathbf{m}} \left((\mu_2^{\mathbf{a}})^{T_1 - 1}, \dots, (\mu_2^{\mathbf{a}})^{T_t - 1}, \text{id}_{\mathbf{m}} \right)$$

To the tree $G^i = (G_1^i, \dots, G_{c_i}^i)$ in the right forest, we assign the operation

$$\mu(G^i) = \mu_{c_i}^{\mathbf{m}} \left((\mu_2^{\mathbf{a}})^{G_1^i - 1}, \dots, (\mu_2^{\mathbf{a}})^{G_{c_i}^i - 1}, \text{id}_{\mathbf{m}} \right)$$

We then build the operation for the whole triple by composing $\mu(F^i)$, $\mu(T)$ and $\mu(G^i)$ in the same order as the trees appear in the triple. \square

Informally, the right forest G is what happens before we map, the middle tree T is the map itself, and the left forest F is what happens after we map. Below is an example triple corresponding to $\mu_1^{\mathbf{m}}(\text{id}_{\mathbf{a}}, \mu_1^{\mathbf{m}}(\mu_2^{\mathbf{a}}, f_2(\mu_2^{\mathbf{a}}, \text{id}_{\mathbf{m}})))$.

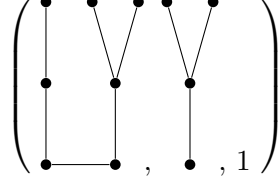

To describe the differential, we need to modify the definition of the transformation S in the case when it is applied to the branch pair in the middle tree, because two trees cannot both remain in the middle. Set $S_l((F, T, G), B) = (F \circ T_l, T_r, G)$ and $S_r((F, T, G), B) = (F, T_l, T_r \circ G)$. Now for B any neighbouring pair of branches is (F, T, G) , define

$$S((F, T, G), B) = \begin{cases} (S(F, B), T, G) & B \subset F \\ S_l((F, T, G), B) + S_r((F, T, G), B) & B \subset T \\ (F, T, S(G, B)) & B \subset G \end{cases}$$

Proposition 3.2.24. Under the correspondence of Prop. 3.2.23, the differential of T is this:

$$d(F, T, G) = \sum_B \pm U((F, T, G), B) + \sum_B \pm S((F, T, G)B) + (F \circ T, 1, G) + (F, 1, T \circ G)$$

where in both sums B runs along the set of neighbouring branch pairs anywhere in the triple. The operadic bimodule structure is given either by forest concatenation when composing with operations in $\Omega(\mathbf{a}^n, \mathbf{m}; \mathbf{m})$ or by leaf multiplication when composing with operations in $\Omega(\mathbf{a}^n; \mathbf{a})$.

3.3 Associahedra and multiplihedra

3.3.1 Associahedra

It is a well known fact that the DG operad A_∞ is obtained by the functor of cellular chains from a CW-operad of *Stasheff associahedra* (see [Sta] and [Tam]).

Definition 3.3.1. An abstract polytope $\mathcal{K}(n)$ has faces corresponding to planar trees with n leaves. The face T is a subspace of the face T' if T' can be obtained from T by contracting inner edges. Viewed as an \mathbb{N} -sequence in the category of CW-complexes, \mathcal{K} has an operadic structure given by tree grafting.

Proposition 3.3.2. $C_*(\mathcal{K}) = A_\infty$. Under this isomorphism, the n -corolla corresponds to μ_n .

$\mathcal{K}(1)$ and $\mathcal{K}(2)$ are points. The pictures below show the interval $\mathcal{K}(3)$ and the pentagon $\mathcal{K}(4)$, with faces labelled by planar trees.

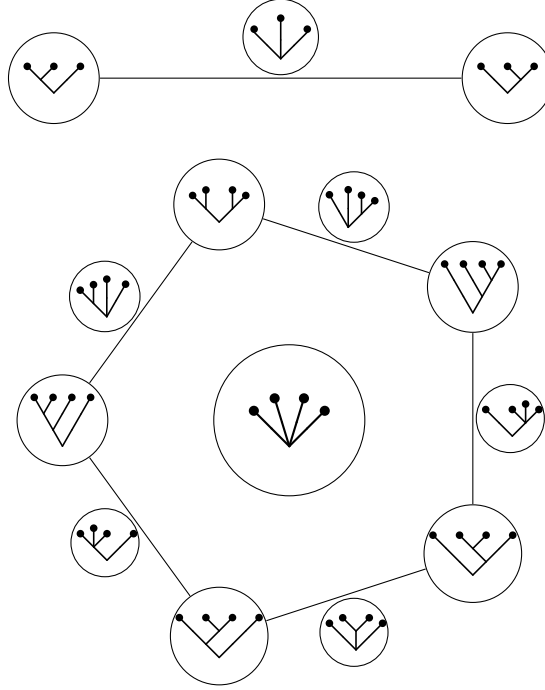

It is a straightforward observation that the (\mathbf{a}, \mathbf{m}) -colored operad A_∞^{Col} can also be obtained from associahedra via cellular chains. Precisely, let \mathcal{K}^{Col} be a colored CW-operad with

$$\begin{aligned} \mathcal{K}^{\text{Col}}(\mathbf{a}^n; \mathbf{a}) &= \mathcal{K}(n); \\ \mathcal{K}^{\text{Col}}(\mathbf{a}^{n-1}, \mathbf{m}; \mathbf{m}) &= \mathcal{K}(n); \\ \emptyset &\text{ elsewhere.} \end{aligned}$$

Then $C_*(\mathcal{K}^{\text{Col}}) = A_\infty^{\text{Col}}$, with the n -corolla of $\mathcal{K}^{\text{Col}}(\mathbf{a}^n; \mathbf{a})$ corresponding to $\mu_n^{\mathbf{a}}$ and with the n -corolla of $\mathcal{K}^{\text{Col}}(\mathbf{a}^{n-1}, \mathbf{m}; \mathbf{m})$ corresponding to $\mu_n^{\mathbf{m}}$.

3.3.2 Multiplihedra

M_∞ , the operadic bimodule over A_∞ , is also obtained by the functor of cellular chains from polytopes \mathcal{J} called *multiplihedra* that form a CW-operadic bimodule over \mathcal{K} . According to [For], multiplihedra admit a description in terms of trees, similar to the description of associahedra.

Definition 3.3.3. A painted planar tree T is a planar tree with a possibility of single-input vertices, and with a selected subtree T_{painted} such that

- the root of T belongs to T_{painted}
- the leaves of T do not belong to T_{painted}
- every single-input vertex of T is a leaf of T_{painted}
- for every vertex of T_{painted} either all inputs are in T_{painted} or all inputs are not in T_{painted}

The picture below shows some examples of such painted trees.

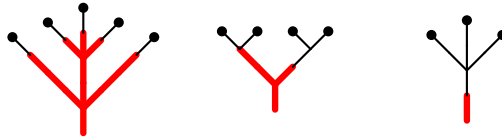

Definition 3.3.4. For a painted tree T , the admissible contractions are:

1. contract an inner edge of T that is unpainted. For example,

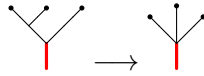

2. contract an edge that is inner to T_{painted} . For example,

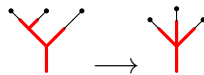

3. contract a corolla of painted leaves. For example,

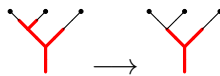

Definition 3.3.5. An abstract polytope $\mathcal{J}(n)$ has faces corresponding to all painted planar trees with n leaves. The face T is a subface of the face T' if T' can be obtained from T by a sequence of admissible contractions. Operadic bimodule structure is again given by tree grafting. For left module structure, the formerly unpainted tree remains unpainted, and for right module structure, the formerly unpainted tree admits the maximal painting.

Below are examples of left and right grafting:

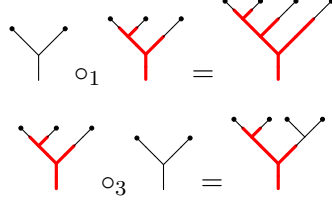

The picture below illustrates the interval $\mathcal{J}(2)$ and the hexagon $\mathcal{J}(3)$, with faces labelled by colored trees.

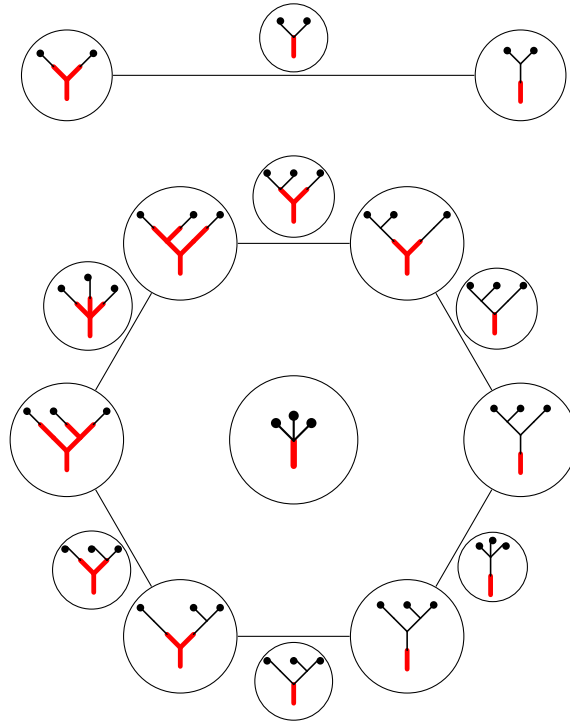

Let C_n denote the painted tree labelling the top-dimensional cell of $\mathcal{J}(n)$. For example, $C_3 = \mathfrak{Y}$.

Proposition 3.3.6. The isomorphism of Prop. 3.3.2 extends to $C_*(\mathcal{K}, \mathcal{J}) = (A_\infty, M_\infty)$, where by (A_∞, M_∞) we mean just the underlying pair. Under this isomorphism, the corolla C_i corresponds to f_i .

Remark 3.3.7. $(\mathcal{K}, \mathcal{J})$ does not form an CW-operadic pair because the map $c: C_*(\mathcal{J}) \rightarrow C_*(\mathcal{J}) \otimes_{C_*(\mathcal{K})} C_*(\mathcal{J})$ involves sums, and one cannot add maps of CW-complexes. In general, the notion of operadic pairs doesn't seem to be well adapted for non-additive categories like Top . However, it is often useful to realize the underlying pair of a DG-operadic pair as cellular chains on a CW-operad with a CW-bimodule.

Similarly to the case of associahedra, we observe that the (\mathbf{a}, \mathbf{m}) -colored bimodule M_∞^{Col} over A_∞^{Col} can also be obtained from multiplihedra via cellular chains. Precisely, let \mathcal{J}^{Col} be a colored CW-sequence with

$$\begin{aligned} \mathcal{J}^{\text{Col}}(\mathbf{a}^n; \mathbf{a}) &= \mathcal{J}(n); \\ \mathcal{J}^{\text{Col}}(\mathbf{a}^{n-1}, \mathbf{m}; \mathbf{m}) &= \mathcal{J}(n); \\ \emptyset &\text{ elsewhere.} \end{aligned}$$

3.3.3 Contraction problem

In the category $\text{DGVect}(\mathbf{k})$ there is a projection of operadic pairs $(A_\infty^{\text{Col}}, M_\infty^{\text{Col}}) \rightarrow (\Omega, T)$. On the polyhedral side, this should correspond to some contraction of associahedra and multiplihedra.

The picture below illustrates how a pentagon $\mathcal{K}(4)$ contracts to a square I^2 , if we remove the non-associativity of the algebra. For readability we label vertices not with binary trees but with expressions in 4 letters.

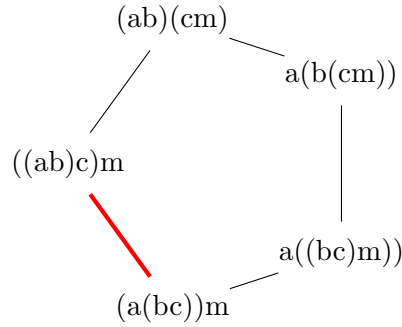

The polyhedral contraction behind $A_\infty^{\text{Col}} \rightarrow \Omega$ was computed, albeit in a different language, in [ACD].

Proposition 3.3.8. $\Omega(\mathbf{a}^n, \mathbf{m}; \mathbf{m}) \simeq C_*(I^{n-1})$, and the projection $A_\infty^{\text{Col}} \rightarrow \Omega$ comes from a projection of associahedra to cubes.

Proof. For a cube I^{n-1} , every face can be written as a word in letters a , b and c , where a is interpreted as $\{0\}$, b is interpreted as $[0, 1]$, c is interpreted as $\{1\}$, and the word is interpreted as their product. For example, for the square the top-dimensional cell is bb , the initial vertex is aa , and the right side is cb . Now, having a short forest, you form the word by setting its i th letter equal to

- a , if the leaves with numbers i and $i + 1$ belong to the same branch
- b , if the leaves with numbers i and $i + 1$ belong to different branches of the same tree

- c , if the leaves with numbers i and $i + 1$ belong to different trees.

□

Note that the above isomorphisms actually arrange the cubes into a CW-operad.

The corresponding contraction of multiplihedra was not previously known, and its computation is a goal of the current paper. The picture below illustrates the two-dimensional case, where a hexagon contracts to a pentagon if $f(ab) = f(a)f(b)$. Warning: this pentagon is not an associahedron, but actually a freehedron.

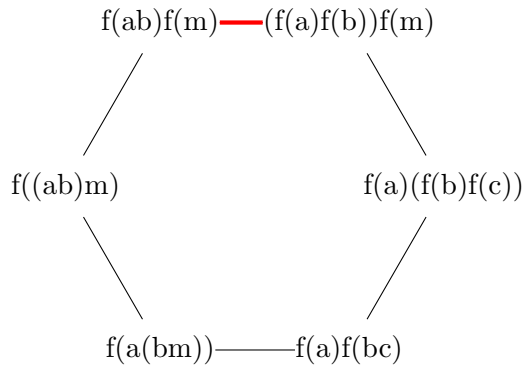

3.4 Freehedra

In this section I present freehedra directly following [San] and [RS]. Consequently I do not include any proofs, but instead include a lot of details and pictures. There are three definitions: as truncations of simplices, as subdivisions of cubes, and a purely combinatorial one. The first definition is not used in the main arguments of this paper, so the reader can safely skip it.

3.4.1 Freehedra as truncations of simplices

The first way to obtain freehedra is to cook them from simplices by applying two sequences of truncations.

Consider the simplex Δ^n in your favourite embedding to \mathbb{R}^n . We now define the first sequence of truncations. Let the original vertices be labelled $0, 1, \dots, n$. After each truncation, some new vertices are cut from edges by the truncating hyperplane; the vertex cut from the edge $a \rightarrow b$ is denoted (ab) .

1. Let Q_0 be a hyperplane that separates 0 from the other vertices. Remove everything connected to 0. The resulting object is a simplicial prism. Its first simplicial face S_1 has vertices $(01), \dots, (0n)$, and the second simplicial face S_2 has vertices $1, \dots, n$.
2. The second hyperplane is like Q_0 but for the $(n-1)$ -simplices S_1 and S_2 simultaneously. It separates (01) and 1 from the other vertices. Denote it by Q_1 and remove everything connected to (01) and 1.

To define all the truncations inductively, denote by $L(k)$ the set of vertices that Q_k separates from the rest. We see that $L(0) = \{0\}$ and $L(1) = \{(01), 1\}$. Now, having an expression for a vertex $v \in L(i-1)$, let $l_i(v)$ be the same expression with $i-1$ replaced by i . For example, $l_2((01)) = (02)$. Now $L(i)$ is defined to consist of vertices $l_i(v)$ and $(vl_i(v))$ for all $v \in L(i-1)$. This defines $Q(i)$, and we proceed to the next step by removing everything at the side of $L(i)$. The final truncation is by Q_{n-2} . We leave it to the interested reader to verify that this sequence of truncations is well-defined.

The second sequence is the same but starting at n instead of 0. Denote the hyperplanes by P_0, \dots, P_{n-2} .

The pictures below show \mathcal{F}_2 and \mathcal{F}_3 cut out of a triangle and a tetrahedron respectively. Note that applying only one of the two truncation sequences yields cubes.

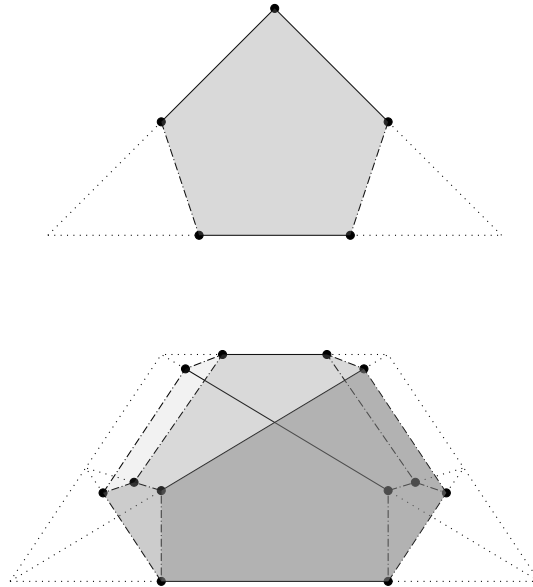

Proposition 3.4.1. Freehedra have two natural projections onto cubes and one natural projection onto simplices.

Proof. All the three projections are obtained by de-truncation (i.e. the procedure opposite to truncation). \square

3.4.2 Freehedra as subdivisions of cubes

The second definition of freehedra is inductive. According to it, each freehedron \mathcal{F}_n is a certain subdivision of $\mathcal{F}_{n-1} \times [0, 1]$, thus all the freehedra arise as drawn on cubes.

We will first present a simplified version of this definition. At each step, the freehedron \mathcal{F}_n will have a distinguished hyperface face X_n . These distinguished faces are only needed for user-friendliness; in the full version of the definition, at each step Saneblidze keeps track of labels for all hyperfaces.

Definition 3.4.2. Let \mathcal{F}_0 be the point, and let \mathcal{F}_1 be the interval $[0, 1]$ with distinguished vertex $X_1 = 1$. Assume \mathcal{F}_{n-1} and its distinguished face X_{n-1} are defined. Consider the polyhedron $\mathcal{F}_{n-1} \times [0, 1]$, and split its hyperface $X_{n-1} \times [0, 1]$ vertically into $X_{n-1} \times [0, \frac{1}{2}]$ and $X_{n-1} \times [\frac{1}{2}, 1]$. This is \mathcal{F}_n . Set $X_n = X_{n-1} \times [\frac{1}{2}, 1]$.

The picture below illustrates freehedra in dimensions 1, 2 and 3. Distinguished hyperfaces are highlighted red.

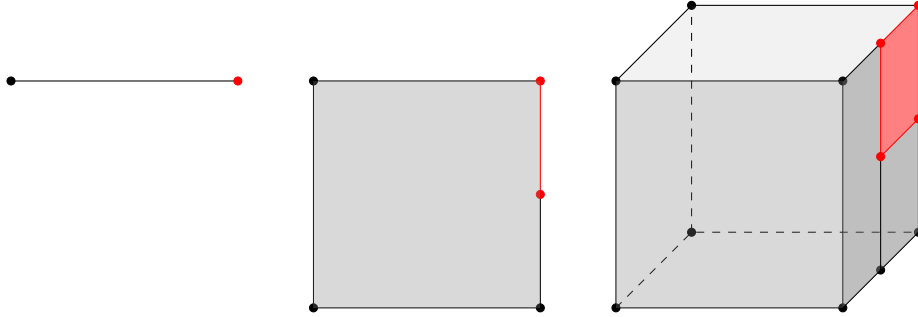

It is useful to have labels for all the hyperfaces. For \mathcal{F}_n , the labels are d_i^0 for $1 \leq i \leq n$, d_i^1 for $2 \leq i \leq n$ and d_i^2 for $1 \leq i \leq n$. The previously defined distinguished hyperface is labelled d_n^2 . The assignment is again given by an inductive procedure. For $1 \leq i \leq n$ and $\epsilon \in \{0, 1\}$, let e_i^ϵ denote the face of the cube $[0, 1]^n$ with coordinates $(x_1, \dots, x_{i-1}, \epsilon, x_{i+1}, \dots, x_n)$. For \mathcal{F}_1 label the vertex 0 by d_1^0 and label the vertex 1 by d_1^1 . Now assume that all the hyperfaces of \mathcal{F}_{n-1} are labelled. Then hyperfaces of \mathcal{F}_n viewed as a subdivision of $[0, 1]^n$ are labelled according to the following table:

Face in $\mathcal{F}_{n-1} \times [0, 1]$	Label in \mathcal{F}_n
$e_i^0, 1 \leq i \leq n$	d_i^0
$e_i^1, 2 \leq i \leq n$	d_i^1
$d_i^2 \times [0, 1], 1 \leq i \leq n-2$	d_i^2
$d_{n-1}^2 \times [0, \frac{1}{2}]$	d_{n-1}^2
$d_{n-1}^2 \times [\frac{1}{2}, 1]$	d_n^2

The picture below illustrates the labels for \mathcal{F}_2 and \mathcal{F}_3 , both in their cubical and simplicial incarnations. The colors in dimension 3 are simply for user-friendliness.

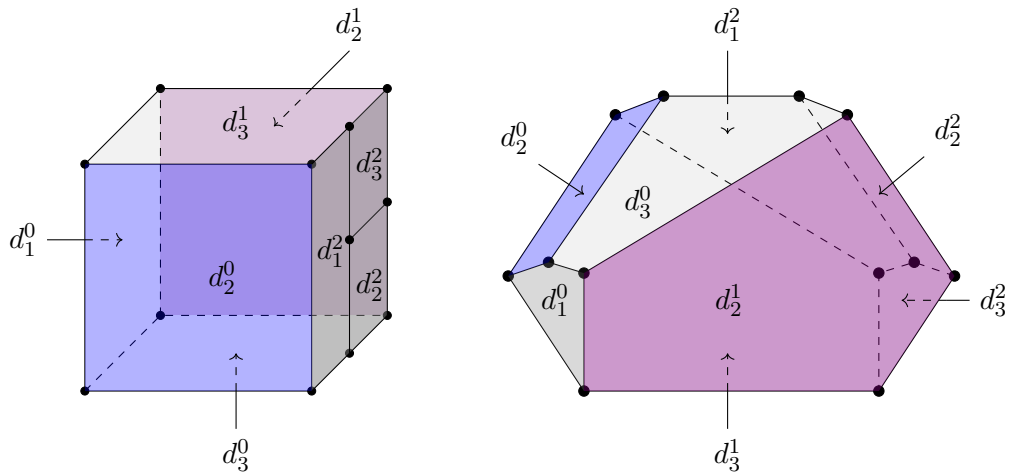
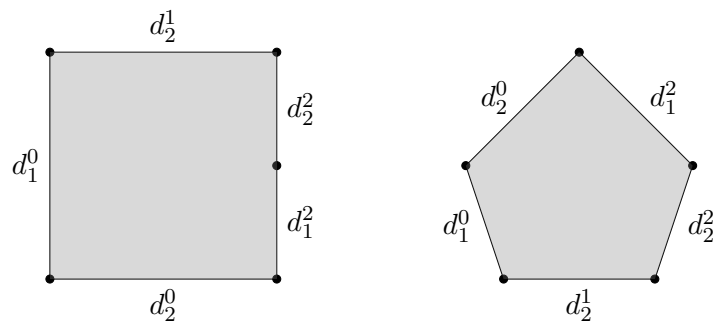

In general, the table below explains which cubic hyperface corresponds to which hyperplane in the truncated simplex. For the hyperface of the original simplex containing all the vertices except for i , the corresponding hyperplane is denoted by D_i .

Cubic label	Hyperplane in simplicial incarnation
$d_i^0, i \leq n-1$	Q_{i-1}
d_n^0	D_n
d_i^1	D_{i-1}
d_1^2	D_0
$d_i^2, i \geq 2$	P_{n-i}

Remark 3.4.3. Cubically interpreted freehedra appear in [Cha], where a surprising connection with Dyck paths is studied.

3.4.3 Freehedra combinatorially

The purely combinatorial definition of freehedra has the benefit that faces of all codimensions obtain labels. These labels are used in the main theorem of the paper.

Definition 3.4.4. A nice n -expression is an expression

$$s = s_l][s_{l+1}] \dots [s_k] |[s_0] \dots [s_{l-1}]$$

where

- (the absence of the opening bracket for s_l is not a typo)
- every stretch s_i is a nonempty subset of $\{0, 1, \dots, n\}$
- for every i , $\max s_i = \min s_{i+1}$
- $|s_i| \geq 2$ if $i \neq l$ ($|s_l| = 1$ is allowed)
- $\min s_0 = 0$ and $\max s_k = n$
- in the case $l = 0$ s_0 is placed to the left of the bar

Every face of \mathcal{F}_n is labelled with a nice n -expression. For a nice expression s as above, let L be the number of elements $i \in \{0, 1, \dots, n\}$ that are not present in s . Then the codimension of the corresponding face is $l + L$.

Examples of such expression for $n = 3$ are $3][[01][13]$ (of codimension $2 + 1 = 3$) or $023|]$ (of codimension $0 + 1 = 1$).

Definition 3.4.5. Consider a nice n -expression s as above:

$$s = s_l][s_{l+1}] \dots [s_k] |[s_0] \dots [s_{l-1}]$$

The *face transformations* that can be applied to s are:

1. Drop: for some stretch s_j remove some $x \in s_j$ with $\min s_j < x < \max s_j$.

2. Inner break: replace some stretch $[s_j]$ with $[s_j^1][s_j^2]$ where $s_j^1 = \{a \leq x | a \in s_j\}$ and $s_j^2 = \{a \geq x | a \in s_j\}$ for some $x \in s_j$ with $\min s_j < x < \max s_j$.
3. Right outer break: replace the stretch $s_l]$ with $s_l^1][s_l^2]$ where $s_l^1 = \{a \leq x | a \in s_l\}$ and $s_l^2 = \{a \geq x | a \in s_l\}$ for some $x \in s_l$ with $x < \max s_l$.
4. Left outer break: for $x \in s_l$ with $\min s_l < x$, replace the stretch $s_l]$ with $\{a \geq x | a \in s_l\}$, and add the stretch $[\{a \leq x | a \in s_l\}]$ to the end of the expression after s_{l-1} .

For example, the expression $23][[012]$ can be transformed into $23][[02]$ by a drop, or into $23][[01][12]$ by an inner break, or into $2][23][[012]$ by a right outer break, or into $3][[012][23]$ by a left outer break.

Definition 3.4.6. In \mathcal{F}_n , a face labelled s' is a codimension 1 subface of a face labelled s if s' can be obtained from s by one of the face transformations.

The resulting abstract polytopes are precisely freehedra. The cubical notation for hyperfaces translates into combinatorial notation for hyperfaces like this:

- d_i^0 corresponds to $0 \dots i-1][i-1 \dots n]$;
- d_i^1 corresponds to $0 \dots \widehat{i-1} \dots n]$, where the hat means the omission;
- d_i^2 corresponds to $i \dots n][[0 \dots i]$.

Below are nice 2-expressions and their face transformation shown on \mathcal{F}_2 . Drops are labelled D, inner breaks are labelled IB, left outer breaks are labelled LOB and right outer breaks are labelled ROB.

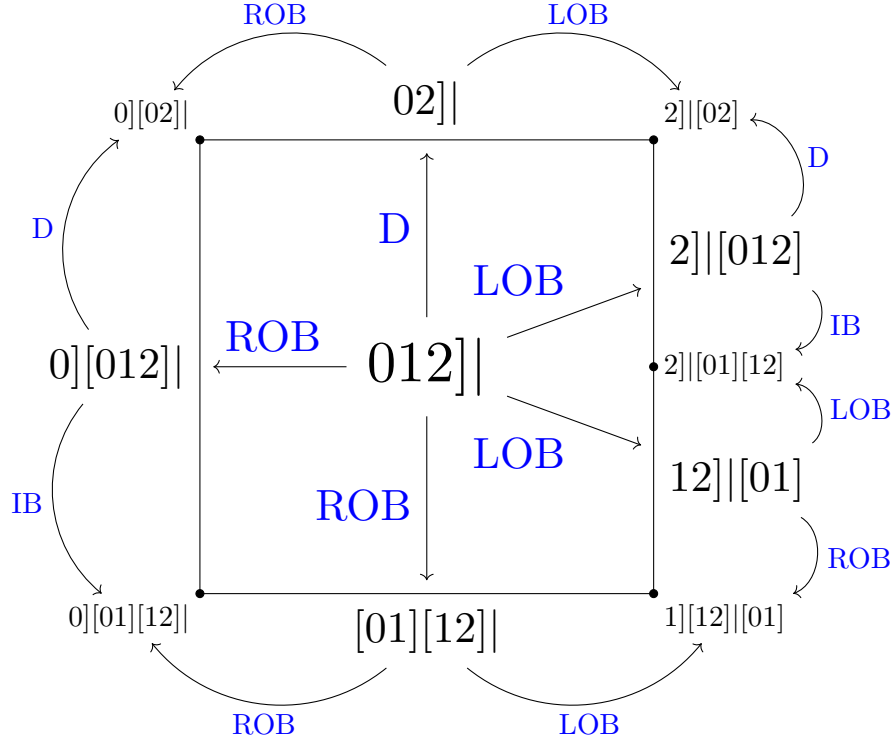

3.5 Main isomorphism

We establish an isomorphism I between the set of nice expressions and the forest-tree-forest basis of T from Prop 3.2.23.

Conjecture 3.5.1. Consider a nice n -expression

$$s = s_l][s_{l+1}] \dots [s_k][s_0] \dots [s_{l-1}]$$

We form the forest-tree-forest triple $I(s) = (F, T, G)$ as follows. Every stretch gives rise to a separate tree. The stretch s_l produces T , the stretches s_i for $i > l$ (located to the left of the bar) produce the trees of F and the stretches s_i for $i < l$ (located to the right of the bar) produce the trees of G . The trees are assembled into the triple in the following order:

$$(F, T, G) = (\iota(s_k) \circ \dots \circ \iota(s_{l+1}), \iota(s_l), \iota(s_{l-1}) \circ \dots \circ \iota(s_0))$$

It remains to explain ι . For a stretch $s = a_1 < \dots < a_m$, $\iota(s)$ is a tree with $m - 1$ branches, where the number of leaves on the j th branch is $a_{j+1} - a_j$.

Proposition 3.5.2. The map I above is a bijection.

Proof. Having a tree-forest-tree triple (F, T, G) with n leaves, we form a nice n -expression $s = I^{-1}(F, T, G)$ as follows. Start from the rightmost branch

of the rightmost tree of G and move left, adding one symbol for one branch within the tree, and beginning the new stretch for the new tree. To form the next symbol of the current stretch, add the number of leaves on the current branch to previous symbol. \square

Proposition 3.5.3. The map I provides an isomorphism of chain complexes

$$C_*(\mathcal{F}_n) \simeq T(\mathbf{a}^n, \mathbf{m}; \mathbf{m})$$

Proof. We only need to verify that the resulting map of graded vector spaces is consistent with differentials. Consider a face of \mathcal{F}_n labelled with a nice n -expression $s = s_l[s_{l+1}] \dots [s_k][s_0] \dots [s_{l-1}]$, with $I(s) = (F, T, G)$. We go through the list of summands in $d(F, T, G)$ from Prop 3.2.23.

1. The summands $U((F, T, G), B)$ for any B correspond to drop transformations.
2. The summands $S((F, T, G), B \subset F)$ correspond to inner break transformations at stretches s_i for $i > l$.
3. The summands $S((F, T, G), B \subset G)$ correspond to inner break transformations at stretches s_i for $i < l$.
4. The summand $(F \circ T, 1, G)$ and the summands $S_l((F, T, G), B \subset T)$ correspond to left outer breaks.
5. The summand $(F, 1, T \circ G)$ and the summands $S_r((F, T, G), B \subset T)$ correspond to right outer breaks.

\square

Therefore we may think of forest-tree-forest triples as another collection of labels for the faces of freehedra. Recall that forests gave a collection of labels for the faces of cubes, as in Prop 3.3.8.

Proposition 3.5.4. Freehedra form an CW-operadic bimodule over the CW-operad of cubes.

Proof. In forest notation, the action is by forest concatenation. \square

The theorem below summarizes the results of this section.

Theorem 3.5.5. The underlying pair of the DG-operadic pair (Ω, T) is $C_*(I, \mathcal{F})$.

3.6 Projections of polyhedra

The operadic interpretation of freehedra equips them with a natural projection from multiplihedra. We now describe it explicitly in terms of painted trees and forest-tree-forest triples. Let T be a painted binary tree corresponding to a vertex of $\mathcal{J}(n)$. The projection $\pi: \mathcal{J}(n) \rightarrow \mathcal{F}(n)$ sends T to a triple $\pi(T) = (F, 1, G)$, where G is formed from the unpainted subtree T' containing the right leaf, and F is formed from $T \setminus T'$ with painting forgotten. The procedure converting these binary trees to forests is the same for T' and $T \setminus T'$.

Conjecture 3.6.1. Having a binary tree, we start from the right leaf and move towards the root. Whenever we encounter a branch B , we create a tree with one branch having as many leaves as eventually belong to the subtree starting at B (the structure of this subtree is forgotten). These trees are arranged into a forest from right to left.

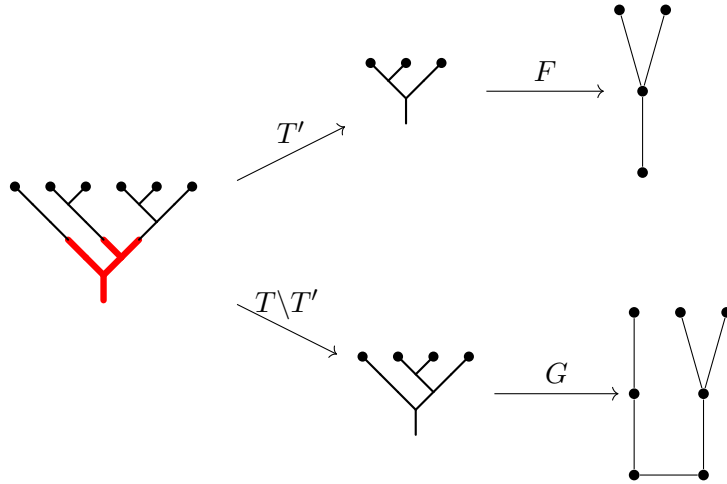

The picture illustrates the construction of $\pi(T)$. The following proposition is now straightforward.

Proposition 3.6.2. The projection $M_\infty^{\text{Col}} \rightarrow T$ is induced by the above projection $\pi: \mathcal{J} \rightarrow T$.

The diagram below summarizes the projections between some families of polyhedra. Note that the projections from freehedra onto cubes and simplices are best seen at the simplicial incarnation of freehedra.

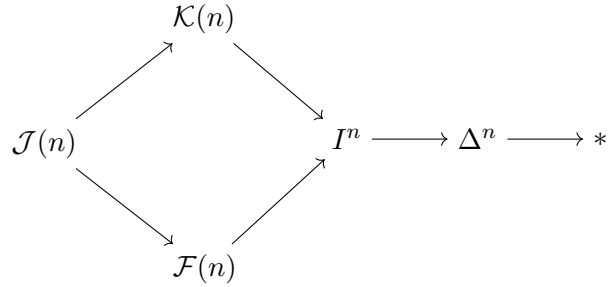

Every family of polytopes in this diagram can be interpreted operadically as the CW-counterpart of the DG-operadic bimodule in a certain (a, m) -colored DG-operadic pair. The partially informal table below lists these interpretations (we denote by B the bimodule responsible for A_∞ -morphisms of DG-modules over DG-algebras).

Polyhedra	Algebras	Modules	Map of algebras	Map of modules	Pair
\mathcal{J}	A_∞	A_∞	A_∞	A_∞	$(A_\infty^{\text{Col}}, M_\infty^{\text{Col}})$
\mathcal{K}	A_∞	A_∞	strict	strict	$(A_\infty^{\text{Col}}, A_\infty^{\text{Col}})$
\mathcal{F}	DG	A_∞	strict	A_∞	(Ω, T)
I	DG	A_∞	strict	strict	(Ω, Ω)
Δ	DG	DG	strict	A_∞	(Ass^{Col}, B)
$*$	DG	DG	strict	strict	$(Ass^{\text{Col}}, Ass^{\text{Col}})$

Proposition 3.6.3. There exists the following diagram of projections between operadic pairs. Applying the functor of cellular chains to the diagram of polyhedral projections yields a part of this diagram – namely, the bimodule part with output \mathbf{m} .

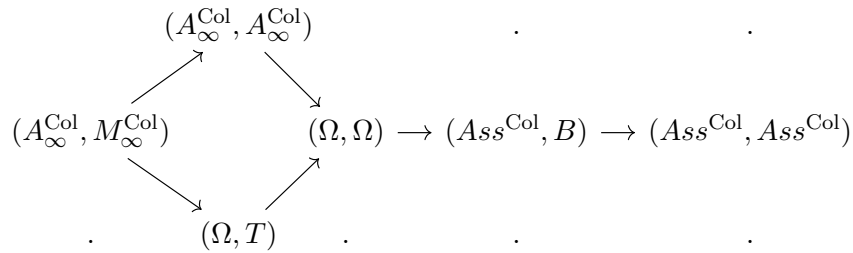

Proof. By direct inspection. \square

Remark 3.6.4. The table above lists not all possible quotients of $(A_\infty^{\text{Col}}, M_\infty^{\text{Col}})$, just the ones that are encountered in real life more frequently than never.

For example, one can also consider the operadic pair controlling A_∞ -modules over DG-algebras, where morphisms are allowed to be A_∞ both for algebras and for modules. This results in a family of where the 3-dimensional polyhedron has polygon score $(0, 8, 0, 4)$ but does not yet appear in the Encyclopedia of Combinatorial Polytope Sequences (maintained by Forcey) yet. So operadic pairs can be used as a tool for obtaining new polyhedral families.

3.7 Hopf operadic pairs

In the closing section we briefly discuss the diagonals for operadic pairs. The category of colored \mathbb{N} -sequences $\mathbb{N}\text{-Seq}_{\text{Col}}(\mathbb{C})$ is equipped with a second tensor product, given by

$$(\mathcal{P} \boxtimes \mathcal{Q})(c_1, \dots, c_n; c) = \mathcal{P}(c_1, \dots, c_n; c) \otimes \mathcal{Q}(c_1, \dots, c_n; c)$$

This tensor product has the property that for an operad \mathcal{P} , $\mathcal{P} \boxtimes \mathcal{P}$ is also an operad. The definition and the proposition below are classical.

Definition 3.7.1. An operad \mathcal{P} is called Hopf if it is equipped with a coassociative diagonal $\Delta_{\mathcal{P}}: \mathcal{P} \rightarrow \mathcal{P} \boxtimes \mathcal{P}$.

Proposition 3.7.2. For a Hopf operad \mathcal{P} , the category $\text{Alg}(\mathcal{P})$ is monoidal.

For any operad \mathcal{P} with an operadic bimodule \mathcal{M} , the sequence $\mathcal{M} \boxtimes \mathcal{M}$ is an operadic bimodule over $\mathcal{P} \boxtimes \mathcal{P}$. For a Hopf operad, one can at both sides restrict along the diagonal $\Delta_{\mathcal{P}}: \mathcal{P} \rightarrow \mathcal{P} \boxtimes \mathcal{P}$, and thus view $\mathcal{M} \boxtimes \mathcal{M}$ as a bimodule over \mathcal{P} itself. This suggests the following new definition.

Definition 3.7.3. An operadic pair $(\mathcal{P}, \mathcal{M})$ is called *strictly* Hopf if Ω is a Hopf operad and there is a coassociative map of counital coalgebras $\Delta_{\mathcal{M}}: \mathcal{M} \rightarrow \mathcal{M} \boxtimes \mathcal{M}$.

Proposition 3.7.4. For a strictly Hopf operadic pair $(\mathcal{P}, \mathcal{M})$, the category $\text{Alg}(\mathcal{P}, \mathcal{M})$ is monoidal.

Proof. The tensor product of objects follows from the Hopf structure on \mathcal{P} via Prop 3.7.2. Consider \mathcal{P} -algebras $X^1 = \{X_c^1\}$, $X^2 = \{X_c^2\}$, $Y^1 = \{Y_c^1\}$ and $Y^2 = \{Y_c^2\}$, with morphisms $f^1: X^1 \rightarrow Y^1$ and $f^2: X^2 \rightarrow Y^2$, given by characteristic maps $\chi_{f^1}: \mathcal{M} \rightarrow \underline{\text{Hom}}_{X^1, Y^1}$ and $\chi_{f^2}: \mathcal{M} \rightarrow \underline{\text{Hom}}_{X^2, Y^2}$. Then the characteristic map $\chi_{f^1 \otimes f^2}: \mathcal{M} \rightarrow \underline{\text{Hom}}_{X^1 \otimes X^2, Y^1 \otimes Y^2}$ is the following composition:

$$\begin{array}{ccc} M & \dashrightarrow & \underline{\text{Hom}}_{X^1 \otimes X^2, Y^1 \otimes Y^2} \\ \downarrow \Delta_{\mathcal{M}} & & \uparrow \\ M \boxtimes M & \xrightarrow{\chi_{f^1} \otimes \chi_{f^2}} & \underline{\text{Hom}}_{X^1, Y^1} \otimes \underline{\text{Hom}}_{X^2, Y^2} \end{array}$$

Associativity of this tensor product follows from coassociativity of $\Delta_{\mathcal{M}}$, and consistency with compositions follows from $\Delta_{\mathcal{M}}$ being a map of coalgebras. \square

Unfortunately, strictly Hopf DG-operadic pairs are rare beasts, with (Ω, T) being an important non-example. Ω is indeed a Hopf operad, with a formula for Δ_{Ω} given in Cor. 5.10 of ACD. The formula for Δ_T is given in Prop. 7.4 of ACD, but this Δ_T is neither coassociative nor a map of coalgebras. Both properties only hold up to homotopy.

The original constructions for Δ_{Ω} and Δ_T are purely algebraic and involve some choices. The results of the current paper suggest that both Δ_{Ω} and Δ_T can be interpreted as known diagonals for polyhedral families. These are obtained with the help of a partial order on faces. Assume that all cubes are embedded into \mathbb{R}^n as $[0, 1]^n$, and that their subdivisions into freehedra are rectangular.

Definition 3.7.5. For v_1 and v_2 vertices either of I^n or of $\mathcal{F}(n)$, we say $v_1 \leq v_2$ if the inequality holds coordinatewise.

Definition 3.7.6. For F_1 and F_2 faces either of I^n or of $\mathcal{F}(n)$, we say $F_1 \leq F_2$ if $\max F_1 \leq \min F_2$.

Then the following formula from Saneblidze defines both the cubic diagonal $\Delta: C_*(I^n) \rightarrow C_*(I^n) \otimes C_*(I^n)$ and the freehedral diagonal $\Delta: C_*(\mathcal{F}(n)) \rightarrow C_*(\mathcal{F}(n)) \otimes C_*(\mathcal{F}(n))$:

$$\Delta(F) = \sum_{\substack{F_1, F_2 \subset F, F_1 \leq F_2 \\ \dim F_1 + \dim F_2 = \dim F}} F_1 \otimes F_2$$

Conjecture 3.7.7. For appropriate choices, Abad-Crainic-Dherin diagonals Δ_{Ω} and Δ_T coincide with Saneblidze diagonals given by the formula above.

The proof requires translating the original constructions of Δ_{Ω} and Δ_T to operadic language, which is technically involved. Thus we delay the proof until the follow up paper, where we define *weakly* Hopf operadic pairs and upgrade $(\Delta_{\Omega}, \Delta_T)$ to weakly Hopf structure.

Bibliography

- [AC] C.A. Abad, M. Crainic. “Representations up to homotopy and Bott’s spectral sequence for Lie groupoids”. *Advances in Mathematics*, 248, 416–452 (2013).
- [ACD] C.A. Abad, M. Crainic, B. Dherin. “Tensor products of representations up to homotopy”. *Journal of Homotopy and Related Structures*, 6(2), 239–288 (2011).
- [Cha] F. Chapoton. “Some properties of a new partial order on Dyck paths”. *Algebraic Combinatorics*, 3(2), 433–463 (2020).
- [For] S. Forcey. “Convex Hull Realizations of the Multiplihedra”. *Topology and its Applications*, 56(2), 326–347 (2008).
- [Kel] B. Keller. “Introduction to A-infinity algebras and modules”. *Homology, Homotopy and Applications*, 3(1), 1–35 (2001).
- [RS] M. Rivera, S. Saneblidze. “A combinatorial model for the free loop fibration”. *Bulletin of the London Mathematical Society*, 50(6), 1085–1101 (2018).
- [San] S. Saneblidze. “The bitwisted Cartesian model for the free loop fibration”. *Topology and its Applications*, 156(5), 897–910 (2009).
- [Sta] J. Stasheff. “Homotopy associativity of H-spaces. I, II”. *Transactions of the American Mathematical Society*, 108, 293–312 (1963).
- [Tam] D. Tamari. “Monoïdes préordonnés et chaînes de Malcev”, Thèse, Université de Paris (1951).

Part III
Projects

Chapter 4

Colored operads from directed polytopes

4.1 Colored operads, Poincaré-Hilbert endomorphisms and duality

4.1.1 Generalities

Recall the terminology and notation for colored operads. For a fixed monoidal category \mathbf{C} and for a fixed set of colors Col (which we assume to be finite), $\mathbb{N}\text{-Seq}_{\text{Col}}(\mathbf{C})$ is the category of colored \mathbb{N} -sequences in \mathbf{C} , where an object \mathcal{P} is a collection of $\mathcal{P}(c_1, \dots, c_k; c) \in \mathbf{C}$ for all tuples c_1, \dots, c_k, c with c_i and c in Col . The colors c_i are called inputs and the color c is called output. For \mathcal{P} and \mathcal{Q} in $\mathbb{N}\text{-Seq}_{\text{Col}}(\mathbf{C})$, their tensor-product $\mathcal{P} \odot \mathcal{Q}$ is given by

$$(\mathcal{P} \odot \mathcal{Q})(c_1, \dots, c_n; c) = \bigoplus_{\substack{i_1 + \dots + i_k = n \\ c'_1, \dots, c'_k \in \text{Col}}} \mathcal{P}(c'_1, \dots, c'_k; c) \otimes \mathcal{Q}(c_1, \dots, c_{i_1}; c'_1) \otimes \dots \otimes \mathcal{Q}(c_{n-i_k+1}, \dots, c_n; c'_k)$$

A colored operad is a unital algebra in $\mathbb{N}\text{-Seq}_{\text{Col}}(\mathbf{C})$. Given unitality, we will often express operadic structure through *elementary* compositions:

$$\begin{aligned} \circ_i: \mathcal{P}(c'_1, \dots, c'_m; c_i) \otimes \mathcal{P}(c_1, \dots, c_n; c) &\rightarrow \\ \mathcal{P}(c_1, \dots, c_{i-1}, c'_1, \dots, c'_m, c_{i+1}, \dots, c_n; c) & \end{aligned}$$

Colored cooperads are defined dually.

Now let $\mathbf{C} = \text{grVect}$ be the category of graded vector spaces that are bounded below and are finitely-dimensional in every graded component. For a colored operad \mathcal{P} in grVect , let $T(\mathcal{P})$ be the algebra of formal power series in non-commuting variables $c \in \text{Col}(\mathcal{P})$, with coefficients in $k((t))$

(this means that the extra invertible variable t is required to commute with everything). For a graded vector space $V = \bigoplus V^i \in \mathbf{grVect}$ let $\dim V$ be the Laurent series in t whose coefficient near t^n is the dimension of V^n .

Definition 4.1.1. The Poincaré-Hilbert endomorphism for \mathcal{P} is an endomorphism f of $T(\mathcal{P})$, which is defined on generators by

$$f(c) = \sum_{c_1, \dots, c_n \in \text{Colors}(P)} \dim P(c_1, \dots, c_n; c) t^{n-1} c_1 \dots c_n$$

This additional multiplication by t^{n-1} ensures that the resulting power of t encodes the *total* gradings of operations, which are sums of inner gradings and arity gradings.

In what follows, we extend our setting to *complexes* of graded vector spaces $\mathbf{Ch}(\mathbf{grVect})$. For $C = \bigoplus C^i$ being such a complex, we define its dimension as $\text{Dim}(C) = \sum (-1)^i \dim C^i$, whenever this Laurent series in t well defined, meaning that the coefficient near each power of t is a finite sum. The definition of Poincaré-Hilbert endomorphism is then repeated verbatim for (co)operads in $\mathbf{Ch}(\mathbf{grVect})$.

We now recall the (reduced) colored operadic Bar construction from [AK].

Definition 4.1.2. A *marked tree* is a planar rooted tree where each edge is decorated with one of the colors $c \in \text{Col}$. Note that inner vertices can have any positive number of incoming edges, including one (stems are allowed). Let $\text{Tree}(c_1, \dots, c_n; c)$ denote the (infinite) set of marked trees where the leaf edges are decorated by c_i and the root edge is decorated by c . For an inner vertex v of such a tree T , let $\text{In}(v)$ denote the string of colors decorating the incoming edges of v , left to right.

Definition 4.1.3. For a colored \mathbb{N} -sequence \mathcal{P} , another colored \mathbb{N} -collection $F(\mathcal{P})$ is defined as

$$\text{Free}(\mathcal{P})(c_1, \dots, c_n; c) = \bigoplus_{T \in \text{Tree}(c_1, \dots, c_n; c)} \bigotimes_{v \in T} \mathcal{P}(\text{In}(v); \text{Out}(v)).$$

This collection is equipped with a map $\text{Free}(\mathcal{P}) \odot \text{Free}(\mathcal{P}) \rightarrow \text{Free}(\mathcal{P})$ giving it the structure of the *free operad* on \mathcal{P} , and with a map $\text{Free}(\mathcal{P}) \rightarrow \text{Free}(\mathcal{P}) \odot \text{Free}(\mathcal{P})$ giving it the structure of the *cofree cooperad* on \mathcal{P} .

An *tree monomial* is a tensor monomial of $\bigotimes_{v \in T} \mathcal{P}(\text{In}(v); \text{Out}(v))$ for some fixed tree T . A tree monomial is called quadratic if the corresponding tree has 2 inner vertices. An homogeneous element of the free colored \mathbb{N} -sequence is called quadratic if it is a sum of quadratic tree monomials.

Now let \mathcal{P} be a colored operad that is *augmented* in the following sense:

$$\mathcal{P} \simeq R \oplus \tilde{\mathcal{P}}$$

where R is the semisimple algebra

$$R \simeq \bigoplus_{c \in \text{Col}(\mathcal{P})} k \cdot 1_c$$

In the present paper, we work with colored operads that allow unary operations in $\tilde{\mathcal{P}}$.

We write $\Sigma\tilde{\mathcal{P}}$ for the suspension that shifts the degree of each complex by minus 1, i.e. $(\Sigma\tilde{\mathcal{P}})(c_1, \dots, c_n; c)^i = \tilde{\mathcal{P}}(c_1, \dots, c_n; c)^{i-1}$ and $d_{\Sigma\tilde{\mathcal{P}}}(v) = (-1)^{|v|} \Sigma(d_{\tilde{\mathcal{P}}}(v))$.

Definition 4.1.4. For the Bar cooperad $\text{Bar}(\mathcal{P})$, its underlying colored collection is $R \oplus \text{Free}(\Sigma\tilde{\mathcal{P}})$. Its differential is obtained by adding a term to the differential on the cofree cooperad, where this extra term encodes the operadic compositions in \mathcal{P} (see 6.3 in [AK]).

In the next subsection we show that under appropriate finiteness conditions on \mathcal{P} , Poincaré-Hilbert endomorphisms of \mathcal{P} and $\text{Bar}(\mathcal{P})$, after some modification of signs, become composition-inverse to each other.

4.1.2 Series inversion

We begin from recalling the well-known formula for series inversion. This is an interpretation of the Faa di Bruno formula, with a proof available e.g. in [AA]. We also present the proof here, because we need to generalize it later. Let f be an endomorphism of $k[[x]]$, given by sending x to the power series $f(x) = x + f_2 x^2 + \dots$ and extending multiplicatively. We would like to obtain an explicit description for the coefficients of g , its composition inverse. The formula is stated in terms of planar trees T that are only allowed to have inner vertices of valency 3 or larger. Denote by $\text{Tree}(n)$ the (finite) set of such trees with n leaves. For a tree with n leaves, set $|T| = n - \#\text{inner edges} - 2$. For any tree T , denote by f_T the product of f_i , where i goes through all the corollas of T .

Theorem 4.1.5. The inverse endomorphism g has coefficients $g_1 = 1$ and, for $n \geq 2$,

$$g_n = \sum_{T \in \text{Tree}(n)} (-1)^{|T|+1} f_T$$

Proof. Consider the result of evaluating $f \circ g$ on x :

$$(x + g_2x^2 + g_3x^3 + \dots) + f_2(x + g_2x^2 + \dots)^2 + f_3(x + \dots)^3 + \dots$$

The coefficient near x is equal to 1. For g to be inverse of f , all other coefficients in the expression above need to vanish. The coefficient of x^n is clearly equal to the sum of $f_k \cdot g_{i_1} \dots g_{i_k}$, for all expressions $i_1 + \dots + i_k = n$ (where f_1 and g_1 should be read as 1). We verify the base of induction: the coefficient near x^2 is $g_2 + f_2$, so $g_2 = -f_2$, which is in agreement with the trees formula (the single 2-leaved tree has $|T| = 2 - 0 - 2 = 0$). Assume that for $k < n$ the above formula for g_k is proved. By evaluating the coefficient near x^n we obtain that

$$g_n = f_1 \cdot g_n = - \sum_{\substack{k \geq 2, \\ i_1 + \dots + i_k = n}} f_k \cdot g_{i_1} \dots g_{i_k}$$

where $i_s < n$ for every s , so we can substitute the values given by inductive assumption. Then we are left to observe that any tree with n leaves can be uniquely constructed out of $k \geq 2$ trees with i_1 to i_k leaves, by adding an edge to the root of each of these smaller trees and gluing at the bottom:

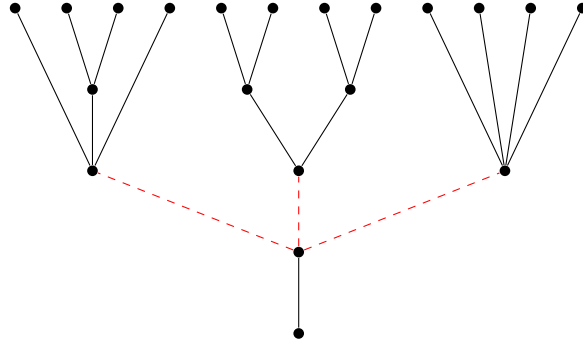

We denote this gluing operation by $*$. Then for $T = T_1 * \dots * T_k$ we have $|T| = |T_1| + \dots + |T_k| + k - 2$, so the signs match, which finishes the proof. \square

We now want to generalize the theorem above in the following directions:

- allow more variables that do not commute
- allow the linear part to be non-identity

So let f be an endomorphism of $T(\mathcal{P})$ as in the previous section. Denote by $f_{c_1 \dots c_n}^c$ the coefficient of the monomial $c_1 \dots c_n$ in the series $f(c)$ (this coefficient is itself a Laurent series in t). Let F be the matrix consisting of

$f_{c'}^c$. For the endomorphism f to have a composition inverse, its linear part F clearly has to be invertible as a matrix. We additionally assume that F can be written in the form $E + \tilde{F}$, where E is the identity matrix and \tilde{F} has only positive powers of t . Then, by elementary algebra, F^{-1} can be written as $\sum_{n \geq 0} (-\tilde{F})^n = E - \tilde{F} + \tilde{F}^2 \dots$. As before, we want an explicit formula for the coefficients of the inverse endomorphism g . This formula is stated in terms of marked trees decorated with out variables. For $T \in \text{Tree}(c_1, \dots, c_n; c)$, let f_T be the product of $f_{\text{In}(v)}^{\text{Out}(v)}$ over all the inner vertices v of T , where $\text{Out}(v)$ is the variable decorating the output edge of v , and $\text{In}(v)$ is the monomial obtained by multiplying together the variables that decorate input edges of v , left to right – with one exception: when $|\text{In}(v)| = 1$, use $\tilde{f}_{\text{In}(v)}^{\text{Out}(v)}$.

Theorem 4.1.6. Let g be the composition inverse of f . Then its coefficient $g_{c_1 \dots c_n}^c$ can be computed by the following formula:

$$g_{c_1 \dots c_n}^c = \sum_{T \in \text{Tree}(c_1, \dots, c_n; c)} (-1)^{|T|+1} f_T$$

Proof. We first deal with linear parts. From the discussion above we know that

$$G = E - \tilde{F} + \tilde{F}^2 - \tilde{F}^3 \dots$$

so, at each place

$$g_c^{c'} = \delta(c, c') - \tilde{f}_c^{c'} + \sum_{c_1 \in C} \tilde{f}_{c_1}^{c'} \tilde{f}_c^{c_1} - \sum_{c_1, c_2 \in C} \tilde{f}_{c_1}^{c'} \tilde{f}_{c_2}^{c_1} \tilde{f}_c^{c_2} + \dots$$

which is precisely the marked trees formula where all involved trees are stems and thus all vertices are binary.

We now proceed by induction on the number of leaves. Assume that for $k < n$, the formulas for $g_{c_1 \dots c_m}^c$ are proved. We look at the coefficient near $x_{c_1} \dots x_{c_n}$ at $g \circ f$ evaluated at x_c . This coefficient is equal to

$$\sum_{c' \in C} f_{c'}^c g_{c_1 \dots c_n}^{c'} + \sum_{\substack{c'_1, \dots, c'_k \in C \\ n = i_1 + \dots + i_k}} f_{c'_1 \dots c'_k}^c g_{c_1 \dots c_{i_1}}^{c'_1} \dots g_{c_{n-i_k+1} \dots c_n}^{c'_k}$$

so for it to vanish, we need the following equality to hold

$$\sum_{c' \in C} f_{c'}^c g_{c_1 \dots c_n}^{c'} = - \sum_{\substack{c'_1, \dots, c'_k \in C \\ n = i_1 + \dots + i_k}} f_{c'_1 \dots c'_k}^c g_{c_1 \dots c_{i_1}}^{c'_1} \dots g_{c_{n-i_k+1} \dots c_n}^{c'_k}$$

We now fix c_1, \dots, c_n but allow c to vary. Then the equations as above assemble into the following:

$$F \cdot g_{c_1 \dots c_n} = - \sum_{\substack{c'_1, \dots, c'_k \in C \\ n = i_1 + \dots + i_k}} f_{c'_1 \dots c'_k} g_{c_1 \dots c_{i_1}}^{c'_1} \dots g_{c_{n-i_k+1} \dots c_n}^{c'_k}$$

where F is the matrix corresponding to the linear part of f , $g_{c_1 \dots c_n}$ is the vector with components $g_{c_1 \dots c_n}^c$, and $f_{c'_1 \dots c'_k}$ is the vector with components $f_{c'_1 \dots c'_k}^c$. We multiply both sides by F^{-1} , which was already shown to control the stems, and insert the coefficients of g that we know by induction. Then on the left hand side we are left just with the vector $g_{c_1 \dots c_n}$ the entries of which we want to know, and the summands on the right hand side bijectively correspond to appropriately marked trees – this can be seen by uniquely decomposing marked trees similarly to the decomposition of unmarked trees as in the proof of Theorem 4.1.5. \square

We obtain an immediate corollary for Poincaré-Hilbert endomorphisms of Bar-dual operads and cooperads.

Corollary 4.1.7. Let I be an endomorphism of $T(\mathcal{P})$ sending each variable c to $-c$, and t to $-t$. For a colored operad \mathcal{P} and its Bar-dual cooperad $\text{Bar}(\mathcal{P})$, we have $f_{\mathcal{P}} \circ I \circ f_{\text{Bar}(\mathcal{P})} \circ I = \text{Id}$.

Note that when all relevant dimensions are finite, a cooperad can be viewed as an operad, by dualizing. Therefore, we can speak of self-dual operads. If an operad \mathcal{P} is self-dual, then the statement above implies that $f_{\mathcal{P}} \circ I$ is an involution. Throughout the paper, this will be referred to as *involution property* of $f_{\mathcal{P}}$.

4.1.3 Koszul duality

If operads are sufficiently nice (namely, Koszul), it is possible to replace Bar duality by quadratic duality, where the latter notion is way more computable. The foundational work here was [GK], although there the authors deal with symmetric operads in one color.

To give the definitions, let us introduce yet another grading on the free operads.

Definition 4.1.8. For a colored \mathbb{N} -collection V with finite-dimensional complexes $V(s_1, \dots, s_n; t)$ and its free colored \mathbb{N} -collection $\text{Free}(V)$, let $\text{Free}(V)\{n\}$ be the subspace of $\text{Free}(V)$ spanned by tree monomials where trees have n inner vertices.

Notice that for every $(s_1, \dots, s_n; t)$ $\text{Free}(V)(s_1, \dots, s_n; t)$ is also finite-dimensional. Now we can recall quadratic operads and their quadratic duals.

Definition 4.1.9. An operad \mathcal{P} is quadratic if it is realized as $\text{Free}(V)/R$, where V is some colored \mathbb{N} -collection and R is an operadic ideal of $\text{Free}(V)$ generated by its intersection with $\text{Free}(V)\{2\}$, or, explicitly,

$$R\{2\} = \bigoplus_{(s_1, \dots, s_n; t)} R\{2\}(s_1, \dots, s_n; t)$$

where $R\{2\}(s_1, \dots, s_n; t) \subset \text{Free}(V)\{2\}(s_1, \dots, s_n; t)$. Such an operad is denoted by $(V, R\{2\})$.

Definition 4.1.10. Given a quadratic colored operad $\mathcal{P} = (V, R\{2\})$. We define the quadratic dual operad $\mathcal{P}^!$ as the quotient of $\text{Free}(V^*)$ by the ideal of relations $R^!$ generated by $R^!\{2\} = \bigoplus_{(s_1, \dots, s_n; t)} R^!\{2\}(s_1, \dots, s_n; t)$ defined as follows. Notice that $\text{Free}(V^*)\{2\}(s_1, \dots, s_n; t)$ is canonically isomorphic to $\text{Free}(V)\{2\}(s_1, \dots, s_n; t)^*$. Now take

$$R^!\{2\}(s_1, \dots, s_n; t) = R\{2\}(s_1, \dots, s_n; t)^\perp.$$

Definition 4.1.11. An operad is Koszul if its quadratic dual $\mathcal{P}^!$ is quasi-isomorphic to its Bar dual.

A useful tool for establishing Koszulity is the theory of Gröbner bases, which we quickly recall. As an input, this theory must take some monomial order.

Definition 4.1.12. A monomial order is a linear order on the set of all tree monomials in some free operad $F(V)$. A monomial order is called admissible if it is

- compatible with arities: for tree monomials $\alpha \in F(V)(c_1, \dots, c_n; c)$ and $\beta \in F(V)(c'_1, \dots, c'_m; c')$ we have $\alpha < \beta$ if $n < m$;
- compatible with compositions: if $\alpha \leq \alpha'$ and $\beta \leq \beta'$ then $\alpha \circ_i \beta \leq \alpha' \circ_i \beta'$ whenever these compositions are defined.

Some standard admissible monomial orders are described in [DK] and [KK].

Now assume that an operad P is written as $F(V)/I$ where F is the free operad on generators V (of arbitrary arities), and I is an operadic ideal. Fix some admissible monomial order. The presence of this monomial order means that for any expression in our generators we can define its *leading term*, i.e. the greatest tree monomial that has a nonzero coefficient in this expression. For an expression f , its leading term will be denoted $\text{lt}(f)$. For an operadic ideal I , $\text{lt}(I)$ is the ideal generated by the leading terms of all elements of I .

Definition 4.1.13. A set of relations $G = \{g_i\}$ is called a Gröbner basis for $P = F(V)/I$, if $I = (G)$ and operadic ideals $\text{lt}(G)$ and $\text{lt}(I) = \text{lt}((G))$ coincide.

We will make use of the following fact, see Corollary 3 in [DK] and Theorem 3.12 in [KK] for the colored case.

Fact 4.1.14. An operad with a quadratic Gröbner basis is Koszul.

There are different ways to check whether a set of relations forms a Gröbner basis. If the dimensions of the components in the operad are already known, then there is a straightforward approach via normal forms.

Definition 4.1.15.

- A tree monomial is a *normal form* with respect to G if it is not divisible by a leading term of any $g \in G$.
- An arbitrary expression in $\text{Free}(V)$ is a normal form if all its monomials are normal forms.

It is true that (the images of) normal forms span the quotient $\text{Free}(V)/(G)$, no matter if G is a Gröbner basis or not. However, if G is a Gröbner basis, the converse is also true.

Fact 4.1.16. G is a Gröbner basis if and only if the number of normal forms in every operadic component coincides with its dimension.

4.2 Main construction

Definition 4.2.1. A polytope P is *directed* if its 1-skeleton is an oriented graph with no cycles, one source and one sink, and the same holds for every face of P .

The conditions above hold for convex polytopes with direction coming from a linear functional, but we consider directed polytopes abstractly. Vertices of a directed polytope are partially ordered: $v_1 \leq v_2$ if there exists a directed edge-path from v_1 to v_2 . This partial order can be extended to a non-reflexive operation on the faces of arbitrary codimension.

Definition 4.2.2. Let F_1 and F_2 be two faces of a directed polytope P . Then $F_1 \leq F_2$ if $\min F_1 \leq \max F_2$.

Note that $F \leq F$ only holds when F is a vertex.

Definition 4.2.3. A sequence of faces (F_1, \dots, F_n) is a *face chain* in a face F if $F_i \subset F$ for any i and $F_1 \leq \dots \leq F_n$. The *excess* of (F_1, \dots, F_n) in F is $(\dim F - 1) - \sum(\dim F_i - 1)$. The set of face chains in F of length n with excess l is denoted by $\text{fc}_l(F, n)$.

Remark 4.2.4. The notion of excess generalizes codimensions. Indeed, for a chain of length 1 the formula gives usual the codimension. Longer chains start having big codimensions if they are not fat enough for their length.

Note that in general, excesses can be both positive and negative: for example, if a 3-dimensional polytope has a chain $F_1 < F_2 < F_3$ of 2-dimensional faces, then this chain would have excess $(3 - 1) - ((2 - 1) + (2 - 1) + (2 - 1)) = -1$. However, cases like this are unwelcome: the theory developed in this paper seems to work well precisely for the polytopes where excesses of nontrivial chains are strictly positive.

We now define \mathcal{O}_P , a colored operad in graded vector spaces associated to the directed polytope P .

Definition 4.2.5. The set of colors is given by all faces of P . The operation spaces are

$$\mathcal{O}_P(F_1, \dots, F_n; F) = \begin{cases} k[l - n + 1] & (F_1, \dots, F_n) \in \mathfrak{fc}_l(F, n) \\ 0 & \text{else} \end{cases}$$

Thus the total grading of every operation is the excess of the corresponding chain. The composition maps are either $k[m] \simeq k[m]$ or $0 \rightarrow k[m]$.

Theorem 4.2.6. \mathcal{O}_P is well-defined.

Proof. We need to verify that we do not encounter a situation when the source of the composition map is nonzero while the target is zero. Once this is verified, the associativity of composition is a tautology. We limit ourselves to pseudoperadic elementary compositions, and thus look at the map \circ_i :

$$\begin{array}{c} \mathcal{O}_P(F_1, \dots, F_n; G_i) \otimes \mathcal{O}_P(G_1, \dots, G_m; G) \\ \downarrow \\ \mathcal{O}_P(G_1, \dots, G_{i-1}, F_1, \dots, F_n, G_{i+1}, \dots, G_m; G) \end{array}$$

Suppose the source of this map does not vanish. This means that (F_1, \dots, F_n) is a face chain of G_i , and (G_1, \dots, G_m) is a face chain of G . Then in the target, the sequence $(G_1, \dots, G_{i-1}, F_1, \dots, F_n, G_{i+1}, \dots, G_m)$ is indeed a face chain of G . Its elements are clearly included in G because the inclusions are composable. The inequality $G_{i-1} \leq F_1$ holds because we have $\max G_{i-1} \leq \min G_i$ from the face chain condition on (G_1, \dots, G_m) and $\min G_i \leq \min F_1$ because $F_1 \subset G_i$. The argument for $F_n \leq G_{i+1}$ is similar. \square

Let us look at the smallest examples.

Example 4.2.7. Let P consist of just one point x . A chain where this point repeats n times has excess $n - 1$. So $\mathfrak{fc}_{n-1}(x, n)$ consists of one chain and $\mathfrak{fc}_l(x, n)$ is empty for $l \neq n - 1$. This means that we have one operation of inner degree 0 in each arity, so $\mathcal{O}_P = \text{Ass}$.

Example 4.2.8. Let P be the interval s with endpoints x and y . Then $\mathfrak{fc}_l(x, n)$ and $\mathfrak{fc}_l(y, n)$ are the same as before. Inside s , there are face chains $x^i s y^j$ with $i + j = n$, $i \geq 0$ and $j \geq 0$, which have excess n , and there are face chains $x^i y^j$ for $i + j = n$, which also have excess n . Algebras over \mathcal{O}_P consist of tuples $(A_x, M_s, A_y, [\])$, where A_x and A_y are associative algebras, M_s is an $A_x - A_y$ bimodule, and $[\]$ is a bilinear form of inner degree 1 on $A_x \otimes A_y$ with values in M_s . Also \mathcal{O}_P has unary operations $x \rightarrow s$ and $y \rightarrow s$, which correspond to maps $A_x \rightarrow M_s$ and $A_y \rightarrow M_s$ – these are suggestively denoted by respectively $[, 1]$ and $[1,]$, though formally they are not expressed through the bracket because our algebras are not unital.

This latter example conveys the general flavour of our construction. For bigger polytopes P , algebras over corresponding operads will consist of multiple associative algebras and bimodules, with various bimodule-valued (not necessarily binary) brackets between them all.

Before moving on, let us take a look at the Poincaré-Hilbert endomorphisms of the operads in the examples above. For the point x , we have

$$f_x = x + tx^2 + t^2x^3 \dots = \frac{x}{1 - tx}$$

For the interval s with endpoints x and y , we have

$$\begin{aligned} f_x &= \frac{x}{1 - tx} \\ f_y &= \frac{y}{1 - ty} \\ f_s &= \frac{1}{1 - xt}(s + (x + y - xy)t)\frac{1}{1 - yt} \end{aligned}$$

It can be checked by a direct computation that both these endomorphisms satisfy the involutive property. This brings us to a conjecture that for some polytopes, their operads are self-dual. We subsequently prove this conjecture for simplices, for products thereof, and for all polygons. In section 4.6 we explain the generality in which we expect the conjecture to hold.

4.3 Functoriality

We now describe the functoriality of our construction.

Let $Poly$ be the category whose objects are directed polytopes, and whose morphisms are inclusions that are injective on face posets and respect directions. The category $Poly$ is monoidal with respect to the obvious product. Let $ColOp$ be the category of colored DG-operads. It is monoidal with respect to the product that multiplies the color sets.

Theorem 4.3.1. The assignment $O : P \mapsto \mathcal{O}_P$ forms a monoidal functor $Poly \rightarrow ColOp$.

Proof. An inclusion of directed polytopes $P \rightarrow Q$ gives a map of operads $\mathcal{O}_P \rightarrow \mathcal{O}_Q$. For two polytopes P_1 and P_2 , we have $\mathcal{O}_{P_1 \times P_2} = \mathcal{O}_{P_1} \times \mathcal{O}_{P_2}$. Both statements are straightforward. \square

4.4 Simplices and cubes

In this section we consider the case of $P = \Delta_n$, the standard simplex. We prove that its operad \mathcal{O}_{Δ_n} is Koszul, by constructing its quadratic Grobner basis. As already mentioned, Koszulity allows us to replace the computationally difficult notion of Bar-duality by a simpler notion of quadratic duality. We then observe quadratic self-duality of \mathcal{O}_{Δ_n} and thus prove the involutive property of its Poincaré-Hilbert series. Functoriality from the previous section also implies the self-duality for operads corresponding to cubes.

We describe the operad \mathcal{O}_{Δ_n} by generators and relations. In a simplex, faces correspond to all nonempty subsets $I \subset [0, n]$ – these are the colors of our operad.

Definition 4.4.1. A binary tree is *right-leaning* if for every inner vertex, its left incoming edge is a leaf.

Lemma 4.4.2. Generating operations for \mathcal{O}_{Δ_n} are of two types: unary and binary. Generating unary operations are elementary inclusions $U_i(I)$ from color I to color $I+i := I \cup \{i\}$, where i is some index outside I . Generating binary operations $B(I, J)$ are from colors I, J to color $I+J := I \cup J$, where I and J are subsets of indices such that $\max I = \min J$. They will be depicted as follows:

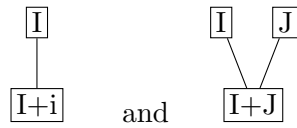

Proof. Consider an arbitrary nonzero operation in \mathcal{O}_{Δ_n} . It goes from colors I_1, \dots, I_k to color I , where $\max I_s \leq \min I_{s+1}$ for every s . We express this operation through U and B as follows. At every color I_s , we apply unary operations appending, in descending order, all indices between $\max I_s$ and $\max I_{s-1}$ that are present in I and not in I_s , up until the moment when we append $\max I_{s-1}$. Then we find ourselves in situation that all colors overlap, so we apply binary operations right to left. Thus our nonzero operation becomes represented by a right-leaning binary tree with stems attached to its leaves, suggestively called *the normal form*. \square

Example 4.4.3. Here is the normal form for the operation from colors $I_1 = 13$, $I_2 = 6$ and $I_3 = 6$ into the color $I = 12346$.

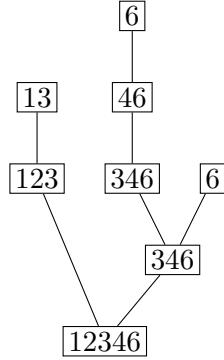

Lemma 4.4.4. Relations on operations U and B are of the following types:

1. for I, J, K with $\max I = \min J$ and $\max J = \min K$, there is a relation $B(B(I, J), K) - B(I, B(J, K))$:

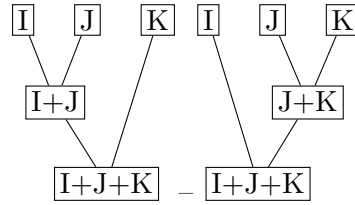

2. for I and J with $\max I < \min J$, there is a relation $B(U_{\min J}(I), J) - B(I, U_{\max I}(J))$:

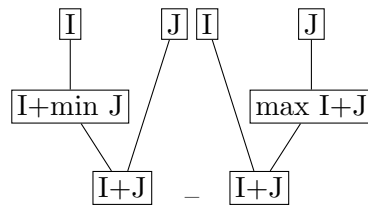

3. for I, J and i with $\max I = \min J$ and $i < \max I$, there is a relation $B(U_i(I), J) - U_i(B(I, J))$:

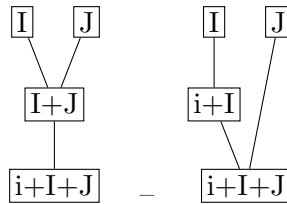

4. for I, J and j with $\max I = \min J$ and $j > \max J$, there is a relation $U_j(B(I, J)) - B(I, U_j(J))$:

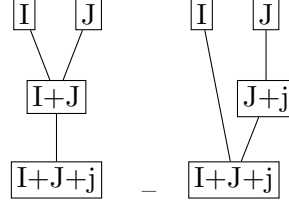

5. for I, i and j with $i < j$, there is a relation $U_i(U_j(I)) - U_j(U_i(I))$:

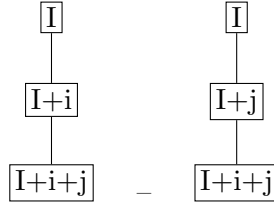

Proof. The relations above are sufficient to bring any tree monomial to the normal form featured in the proof of Lemma 4.4.2. Indeed, relations of type 3 and type 4 can be applied until the moment that all stems become attached to the top of the binary tree. Then relations of type 1 can be applied until the binary tree becomes right-leaning. Then relations of type 2 can be applied until stems become attached to the rightmost possible leaf of the binary tree. And finally, relations of type 5 can be applied until within every stem, the indices are appended in the descending order. \square

To proceed with our proof of Koszulity, we now describe a monomial order on tree monomials consisting of operations U and B . We first order the generating operations in the following way:

- All unary operations are smaller than all binary operations.
- $U_i(I)$ and $U_j(J)$ are first compared by the lengths of I and J ; if lengths coincide, then I and J are compared lexicographically; if $I = J$, then $U_i(I) < U_j(I)$ if $i > j$.
- $B(I, J)$ and $B(I', J')$ are first compared by the length of $I \cup J$ and $I' \cup J'$; if lengths coincide, then $I \cup J$ and $I' \cup J'$ are compared lexicographically; if they coincide, then the length of I is compared to the length of I' .

For example, in O_{Δ_1} the resulting order on generating operations is as follows:

$$U_1(0) < U_0(1) < B(0, 0) < B(1, 1) < B(0, 01) < B(01, 1)$$

We now declare an order on tree monomials. To every tree monomial T with k leaves we associate a sequence $S(T)$ of k words in the alphabet consisting of generating operations. The i th word in this sequence is obtained by going from i th leaf to the root and recording all operations that are encountered on the way. Tree monomials are then compared by their sequences:

- We first compare the number of words/leaves.
- If those coincide, we lexicographically compare vectors encoding word lengths.
- If those coincide, we lexicographically compare first words, then second words and so on until we encounter a difference.

This order on tree monomials is a minor modification of the well-known *path-lexicographic order*, and can be easily checked to be admissible.

Note that the relations in Lemma 4.4.4 are already written in such a way that their leading terms go first. In the computations to follow, this will always be the way to write things.

Theorem 4.4.5. Relations from Lemma 4.4.4 form a quadratic Gröbner basis in O_{Δ_n} .

Proof. In the proof of Lemma 4.4.4 we have explained how any tree monomial with given inputs and given output can be brought to what we have suggestively called its normal form. Now that we have fixed the monomial order, we see that abovementioned normal forms are indeed normal forms with respect to the relations G , and that these are the only normal forms: the applications of relations in the proof of Lemma 4.4.4 precisely correspond to lead-reducing in the those relations. Thus in every colored arity, the number of normal forms coincides with the dimension of the corresponding component of the operad (both being either 0 or 1), so G is a Gröbner basis according to Fact 4.1.16. \square

Alternatively, we could have computed all the S -polynomials and shown that they reduce to 0. Here is an example of such a computation.

For two relations both being of Type 1, their S -polynomial is defined when their leading terms intersect like this:

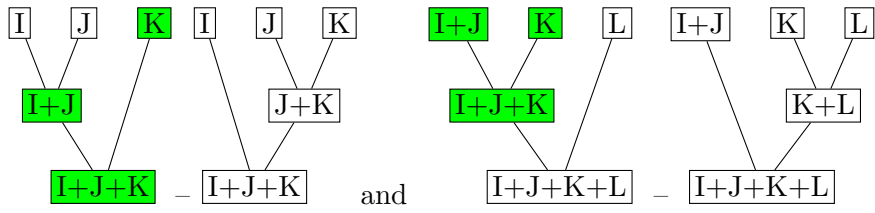

their S-polynomial is this:

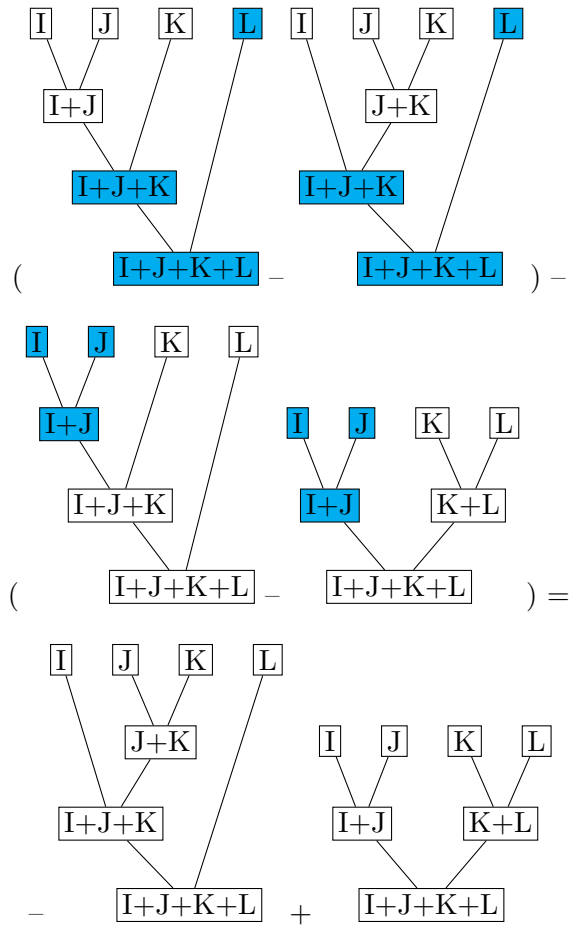

Reducing with respect to

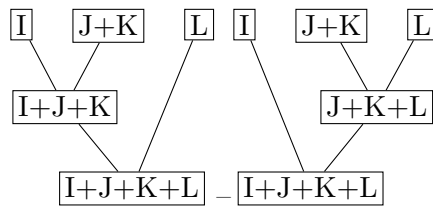

means subtracting

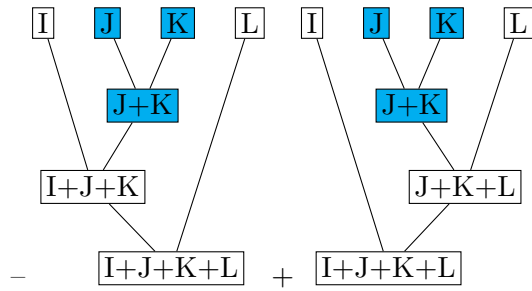

so the reduction is equal to

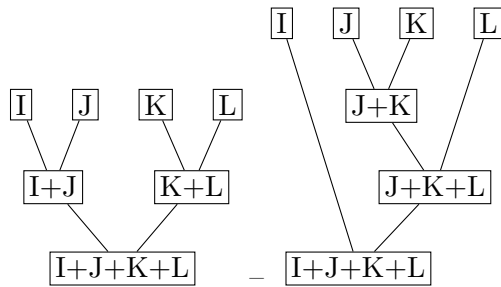

Further reducing with respect to

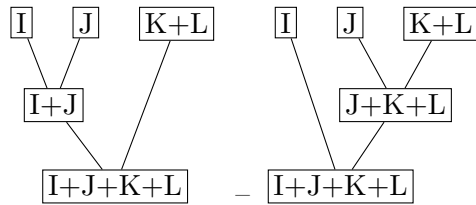

means subtracting

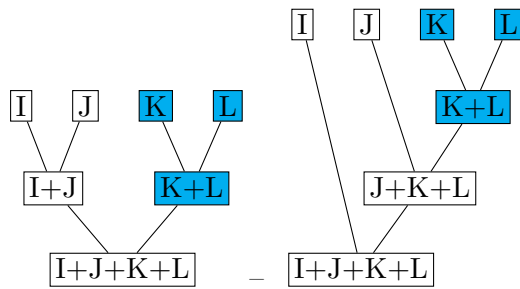

so the reduction is equal to

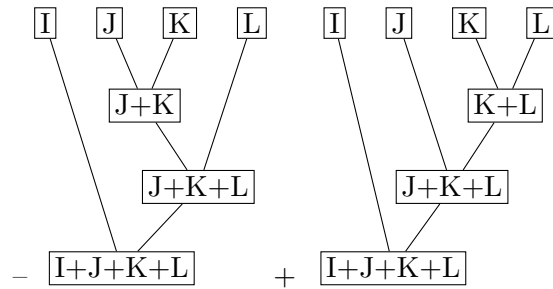

This clearly reduces to 0 with respect to

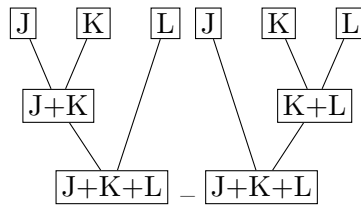

Corollary 4.4.6. Operad O_{Δ_n} is Koszul.

We now compute its quadratic dual.

Theorem 4.4.7. O_{Δ_n} is quadratically self-dual.

Proof. The arities in which quadratic tree monomials are encountered are precisely the arities listed in Lemma 4.4.4 (note that non-quadratic monomials are not encountered in those arities). In each of those arities, there are two possible tree monomials and one relation, equal to the difference of those two. So essentially the argument is the same as in proving that the associative operad is quadratically self-dual. \square

Corollary 4.4.8. Operad O_{Δ_n} is Bar self-dual, and its Poincaré-Hilbert endomorphism satisfies the involutive property.

Note that a cube with standard directions is simply a product of several intervals. Thus the functoriality from the previous section also implies the statement for all cubes.

Corollary 4.4.9. For a cube I^n , its operad O_{I^n} is Bar self-dual, and its Poincaré-Hilbert endomorphism satisfies the involutive property.

4.5 Polygons

For polygons larger than the triangle, generating operations may be of arbitrary arity, but relations remain quadratic. So this section is structurally indistinguishable from the previous section, only the description of normal

forms is a bit less pleasant.

Let P be a polygon, with the source vertex labelled by $0 = x(0) = y(0)$, the sink vertex labelled by $1 = x(n+1) = y(m+1)$, vertices of the upper path labelled by $x(1)$ to $x(n)$, edges of the upper path labelled by $e(0)$ to $e(n)$, vertices of the lower path labelled by $y(1)$ to $y(m)$ and edges of the lower path labelled by $f(0)$ to $f(m)$:

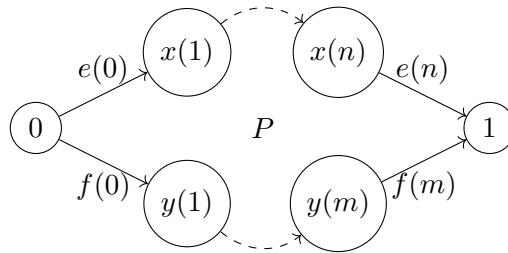

Lemma 4.5.1. Generating operations for O_P are of the following types:

1. left vertex inclusions $U_{\text{left}}(x(i))$ and $U_{\text{left}}(y(i))$:

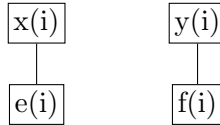

2. right vertex inclusions $U_{\text{right}}(x(i))$ and $U_{\text{right}}(y(i))$:

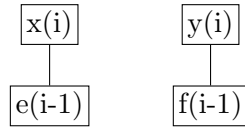

3. vertex-vertex actions $B(x(i), x(i))$ and $B(y(i), y(i))$:

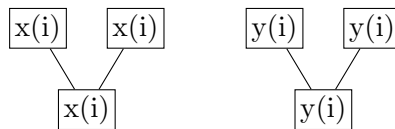

4. vertex-edge actions $B(x(i), e(i))$ and $B(y(i), f(i))$:

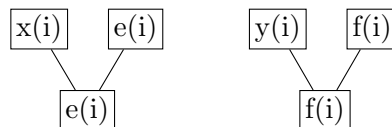

5. edge-vertex actions $B(e(i-1), x(i))$ and $B(f(i-1), y(i))$:

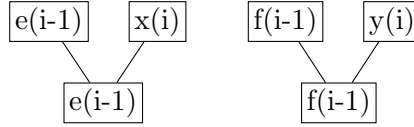

6. 0-action $B(0, P)$:

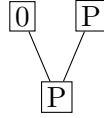

7. 1-action $B(P, 1)$:

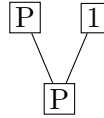

8. edge-sequences (note that the sequence of edges may be of length 1, to account for edge inclusions, or may be disconnected) $M(e(i_1), \dots, e(i_k))$ and $M(f(i_1), \dots, f(i_k))$ for $i_1 < \dots < i_k$:

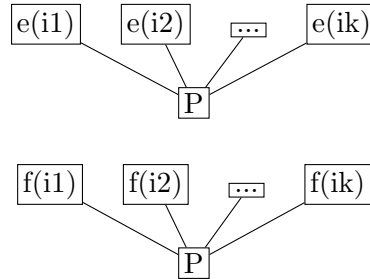

Proof. We only have to deal with operations that have output P (operations with other outputs are covered by considerations for simplices). Consider a nonzero operation whose inputs are the sequence σ , consisting of: several (maybe none) instances of 0, then some sequence of edges and vertices along the upper path, then several (maybe none) instances of 1. For every vertex v along the upper path, we define its subword σ_v as follows:

- $\sigma_{x(i)}$ for $i < n$ consists of all instances of $x(i)$ in σ , and of $e(i)$ if $e(i)$ is in σ
- $\sigma_{x(n)}$ consists of all instances of $x(n)$ in σ , of $e(n)$ whenever it is in σ , and of all instances of 1 in σ

- σ_1 is empty when $\sigma_{x(n)}$ is nonempty; otherwise it consists of $e(n)$ whenever it is in σ and of all instances of 1 in σ

Thus σ is represented as a concatenation of subwords σ_v (ignore the empty ones). For every subword $\sigma_{x(i)}$ with $0 < i < n$, we apply generators in one of the following ways, depending on whether $e(i)$ is already in $\sigma_{x(i)}$ or not, to obtain an operation with output $e(i)$:

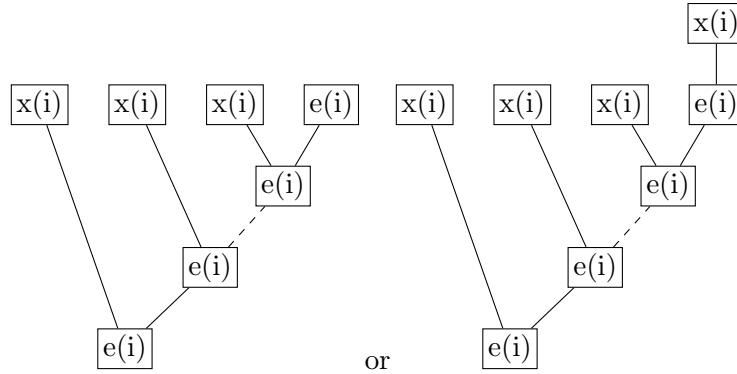

For the subword $\sigma_{x(n)}$ (or for σ_1 , depending on which one is nonempty) we apply generators in one of the following ways, depending on whether $e(n)$ is already in the subword or not:

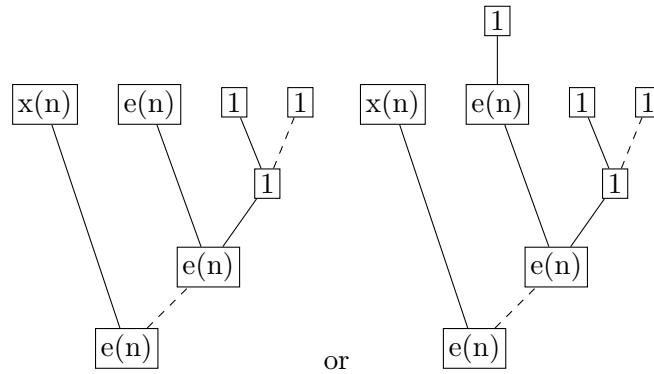

Then we apply an operation with inputs $e(0)$ (if it is in σ) and $\{e(i_s)\}$ (where $e(i_s)$ are outputs of the operations described above), and with output P . And finally, we apply 0-action as many times as needed to deal with σ_0 . As with the simplices, this particular tree monomial is suggestively called the normal form (which it will be, after we fix the monomial order and write out the relations).

The case of lower path is identical, after replacing x with y and e with f . □

Example 4.5.2. Consider the case of $n = 2$ and $\sigma = (0, 0, e(0), x(1), x(1), x(2), e(2), 1)$. Then the subwords are $\sigma_0 = (0, 0, e(0))$, $\sigma_{x(1)} = (x(1), x(1))$, $\sigma_{x(2)} = (x(2), e(2), 1)$, and the corresponding normal form is this:

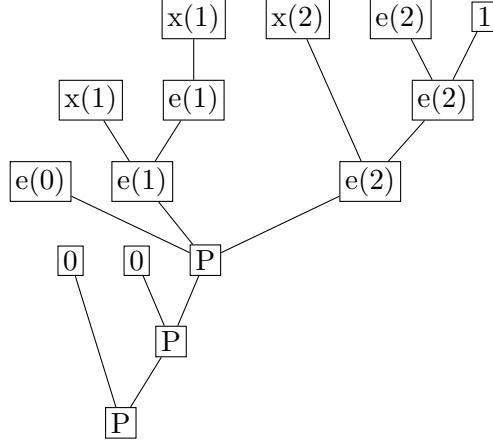

Informally, all of this was to say: for the normal form we choose the most right-leaning tree of all.

In the following lemma we list the (straightforward though tiresome to write) relations arising on quadratic tree monomials.

Lemma 4.5.3. Relations G on the generating operations are of the following types:

1. generalized simple associativities, i.e. relations of the type

$$B(?, B(?, ?)) - B(B(?, ?), ?)$$

where arity is one of the following:

- $(x(i)^3; x(i))$ or $(y(i)^3; y(i))$
- $(x(i)^2, e(i); e(i))$ or $(y(i)^2, f(i); f(i))$
- $(x(i), e(i), x(i+1); e(i))$ or $(y(i), f(i), y(i+1); f(i))$
- $(e(i), x(i+1)^2; e(i))$ or $(f(i), y(i+1)^2; f(i))$
- $(0^2, P; P)$
- $(P, 1^2; P)$

2. in arity $(0, e(0), e(i_1), \dots, e(i_s); P)$ or $(0, f(0), f(i_1), \dots, f(i_s); P)$ for $0 < i_1 < \dots < i_s$:

$$B(0, M(e(0), e(i_1), \dots, e(i_s))) - M(B(0, e(0)), e(i_1), \dots, e(i_s))$$

or

$$B(0, M(f(0), f(i_1), \dots, f(i_s))) - M(B(0, f(0)), f(i_1), \dots, f(i_s))$$

3. in arity $(0 = x(0), e(i_1), \dots, e(i_s); P)$ or $(0 = y(0), f(0), \dots, f(i_s); P)$ for $0 < i_1 < \dots < i_s$:

$$B(x(0), M(e(i_1), \dots, e(i_s))) - M(U_{\text{left}}(x(0)), e(i_1), \dots, e(i_s))$$

or

$$B(y(0), M(f(i_1), \dots, f(i_s))) - M(U_{\text{left}}(y(0)), f(i_1), \dots, f(i_s))$$

4. in arity $(e(i_1), \dots, e(i_s), e(n), 1; P)$ or $(f(i_1), \dots, f(i_s), f(n), 1; P)$ for $i_1 < \dots < i_s < n$:

$$M(e(i_1), \dots, e(i_s), B(e(n), 1)) - B(M(e(i_1), \dots, e(i_s), e(n)), 1)$$

or

$$M(f(i_1), \dots, e(f_s), B(f(n), 1)) - B(M(f(i_1), \dots, f(i_s), f(n)), 1)$$

5. in arity $(e(i_1), \dots, e(i_s), 1 = x(n+1); P)$ or $(f(i_1), \dots, f(i_s), 1 = y(m+1); P)$ for $i_1 < \dots < i_s < n$:

$$M(e(i_1), \dots, e(i_s), U_{\text{right}}(x(n+1))) - B(M(e(i_1), \dots, e(i_s)), x(n+1))$$

or

$$M(f(i_1), \dots, f(i_s), U_{\text{right}}(y(m+1))) - B(M(f(i_1), \dots, f(i_s)), y(m+1))$$

6. in arity $(e(i_1), \dots, e(i_a), x(j), e(i_{a+1}), \dots, e(i_s); P)$ or $(f(i_1), \dots, f(i_a), y(j), f(i_{a+1}), \dots, f(i_s); P)$ for $i_1 < \dots < i_s$ and $i_a + 1 < j < i_{a+1}$:

$$M(e(i_1), \dots, e(i_a), U_{\text{left}}(x(j)), e(i_{a+1}), \dots, e(i_s)) - \\ M(e(i_1), \dots, e(i_a), U_{\text{right}}(x(j)), e(i_{a+1}), \dots, e(i_s))$$

or

$$M(f(i_1), \dots, f(i_a), U_{\text{left}}(y(j)), f(i_{a+1}), \dots, f(i_s)) - \\ M(f(i_1), \dots, f(i_a), U_{\text{right}}(y(j)), f(i_{a+1}), \dots, f(i_s))$$

7. in arity $(e(i_1), \dots, e(i_a), x(i_a), e(i_{a+1}), \dots, e(i_s); P)$ or $(f(i_1), \dots, f(i_a), y(i_a), f(i_{a+1}), \dots, f(i_s); P)$ for $i_1 < \dots < i_s$:

$$M(e(i_1), \dots, B(e(i_a), x(i_a)), e(i_{a+1}), \dots, e(i_s)) - \\ M(e(i_1), \dots, e(i_a), U_{\text{left}}(x(i_a)), e(i_{a+1}), \dots, e(i_s))$$

or

$$M(f(i_1), \dots, B(f(i_a), y(i_a)), f(i_{a+1}), \dots, f(i_s)) - \\ M(f(i_1), \dots, f(i_a), U_{\text{left}}(y(i_a)), f(i_{a+1}), \dots, f(i_s))$$

8. in arity $(e(i_1), \dots, e(i_a), x(i_{a+1} + 1), e(i_{a+1}), \dots, e(i_s); P)$ or $(f(i_1), \dots, f(i_a), y(i_{a+1} + 1), f(i_{a+1}), \dots, f(i_s); P)$ for $i_1 < \dots < i_s$:

$$\begin{aligned} &M(e(i_1), \dots, B(x(i_a + 1), e(i_{a+1})), \dots, e(i_s)) - \\ &M(e(i_1), \dots, e(i_a), U_{\text{right}}(x(i_a + 1)), e(i_{a+1}), \dots, e(i_s)) \end{aligned}$$

or

$$\begin{aligned} &M(f(i_1), \dots, B(y(i_a), f(i_{a+1})), \dots, f(i_s)) - \\ &M(f(i_1), \dots, U_{\text{right}}(y(i_a + 1)), f(i_{a+1}), \dots, f(i_s)) \end{aligned}$$

9. in arity $(e(i_1), \dots, e(i_a), x(i_a + 1), e(i_{a+1}), \dots, e(i_s); P)$ or $(f(i_1), \dots, f(i_a), y(i_a + 1), f(i_{a+1}), \dots, f(i_s); P)$ for $i_1 < \dots < i_s$ and $i_a + 1 = i_{a+1}$:

$$\begin{aligned} &M(e(i_1), \dots, B(e(i_a), x(i_a + 1)), \dots, e(i_s)) - \\ &M(e(i_1), \dots, B(x(i_a + 1), e(i_{a+1})), \dots, e(i_s)) \end{aligned}$$

or

$$\begin{aligned} &M(f(i_1), \dots, B(f(i_a), y(i_a + 1)), \dots, f(i_s)) - \\ &M(f(i_1), \dots, B(y(i_a + 1), f(i_{a+1})), \dots, f(i_s)) \end{aligned}$$

Proof. As before, we show that these relations are sufficient to bring any tree monomial to its normal form described in the proof of Lemma 4.5.1. We delay the description of this procedure until we have defined the monomial order, so that we could simultaneously prove that G is a Gröbner basis. \square

Similarly to the previous section, we derive path-lexicographic order on all tree monomials from the following order on generating operations:

- operation of a smaller arity is smaller
- for unary operations, $U_{\text{right}} < U_{\text{left}} < M(e)$
- for binary operations, we first compare outputs: vertices are smaller than edges, edges are smaller than P , vertices and edges are ordered left to right; if outputs coincide, we compare the input sequences lexicographically.
- for operations $M(\sigma)$ and $M(\sigma')$ with $|\sigma| = |\sigma'| > 2$ the sequences σ and σ' are compared lexicographically.

Theorem 4.5.4. Relations from Lemma 4.5.3 form a quadratic Gröbner basis of \mathcal{O}_P .

Proof. Similarly to the case of simplices, we observe that normal forms described above are irreducible with respect to G and are the only tree monomials of given arities with this property, thus the number of normal forms coincides with the dimension of the respective operadic component. Indeed, let T be a tree monomial of arity $(\sigma; P)$, with σ being a sequence as in the proof of Lemma 4.5.1.

1. By lead-reducing in relations of types 1, 2 and 3 we can bring T to the form

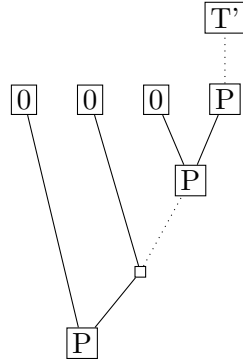

where rooted at P , there is a tree monomial T' with its inputs σ' devoid of 0. We now work with T' .

2. By lead-reducing in relations of types 4 and 5, we bring T' to the form where the bottom operation is M :

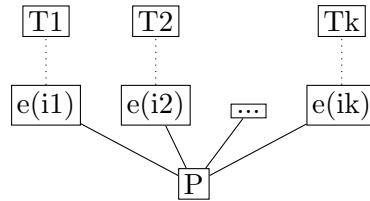

3. By lead-reducing in relations of types 6, 7, 8 and 9, we ensure that every nonterminal vertex appearing in σ belongs to the subtree T_i whose root is an edge $e(i_l)$ to the right of this vertex.
4. Finally, by read-reducing again in relations of type 1, we ensure that trees T_i are right-leaning.

□

Corollary 4.5.5. The operad \mathcal{O}_P is Koszul.

Theorem 4.5.6. The operad \mathcal{O}_P is quadratically self-dual.

Proof. Similarly to the case of the simplices, the arities in which quadratic tree monomials are encountered are precisely the arities listed in Lemma 4.5.3, with no non-quadratic tree monomials in these arities. In each of these arities, there are two possible tree monomials and one relation, equal to the difference of those two, so again the argument is a generalization of the argument for self duality of the associative operad. \square

Corollary 4.5.7. The operad \mathcal{O}_P is Bar self-dual, and its Poincaré-Hilbert endomorphism satisfies the involutive property.

4.6 Shortness and integrated A_∞ -coalgebras

We now explain the generality in which we expect the self-duality conjecture to hold.

Definition 4.6.1. A directed polytope P is called short if nontrivial chains have positive excesses.

In terms of operads, shortness has a very precise meaning: for a short polytope P , its operad \mathcal{O}_P is nonnegatively graded with respect to the *total* grading, with \mathcal{O}_P^0 being just the semisimple algebra $R = \bigoplus k \cdot 1_F$.

Conjecture 4.6.2. For short polytopes their operads are Koszul and Koszul self-dual.

Examples of short polytopes include simplices and polygons. Products of short polytopes are also short, thus adding cubes into this class.

Our evidence for the Conjecture 4.6.2, besides proved results for simplices and polygons, includes Sage verification of the involutive property of the Poincaré-Hilbert endomorphism of \mathcal{O}_P for P several non-standard directions of 3D cube, pyramid and octahedron. The involutive property held for all short polytopes and failed for all non-short polytopes.

Now suppose that there is some magician to fix all the signs for us. Formally, let us work over \mathbb{F}_2 (although we expect our theory to work generally). Let P be a short polytope, and let $C_*(P)$ be the *graded vector space* of cellular chains. Consider the degree k maps

$$\Delta_n^k : C_*(P)[1] \rightarrow C_*(P)[1]^{\otimes n}$$

$$F \mapsto \sum_{(F_1, \dots, F_m) \in \text{fc}_k(F, n)} F_1 \otimes \dots \otimes F_n$$

where the face generator F maps to the sum of tensor products of chains in F that have length n and excess k . For example, Δ_1^0 is the identity map and Δ_1^1 is the cellular differential. A more interesting observation: for the case of simplices, Δ_2^1 is the diagonal that governs the multiplication in singular cohomology, and for the case of cubes, Δ_2^1 is the Serre diagonal.

The following (elementary but surprising) theorem explains the connection of the theory built in the present paper with A_∞ -world (see [Kel] for exposition).

Theorem 4.6.3. Shortness condition and self-duality of \mathcal{O}_P together imply that operations Δ_n^1 for $n \geq 1$ assemble into A_∞ -coalgebra structure on $C_*(P)$.

Proof. The Poincaré-Hilbert endomorphism can be written as a t -linear endomorphism of $\widehat{T}(C_*(P)[1])[[t]]$ which is, on generators, given by

$$\text{Id} + \Delta^1 t + \Delta^2 t^2 + \dots$$

where Δ^k is the sum $\sum_{n \geq 1} \Delta_n^k$. The involutive property says that, modulo signs, this is an involution. So if we extend Δ^1 from generators as a derivation, it would square to 0 (note that we use working modulo 2 when we say $\text{Id} \Delta^2 + \Delta^2 \text{Id} = 0$). This is precisely the compact definition of A_∞ -relations. \square

Remark 4.6.4. For the theory to work with signs, we certainly need to replace identity with parity; putting signs in order is a work in progress.

Therefore, vector spaces V such that with $T(V[1])$ is equipped with a t -involution can be viewed as *integrated A_∞ -coalgebras*.

Our original goal was to apply this machinery for associahedra with Tamari directions. Unfortunately, in dimensions ≥ 4 they fail to be short (though all chains of length 2 do have positive excesses, thus allowing the SU-diagonal [SU] to satisfy Leibniz rule). A further direction of our research is to develop a modification of \mathcal{O}_P -construction that would provide a positively graded Koszul self-dual operad for associahedra.

Bibliography

- [AA] M. Aguiar, F. Ardila. “Hopf monoids and generalized permutahedra”, arXiv:1709.07504 (2017).
- [AK] S. Arkhipov, T. Kanstrup. “Colored DG-operads and homotopy adjunction for DG-categories”. arXiv: 1806.10103 (2018).
- [DK] V. Dotsenko, A. Khoroshkin, “Gröbner bases for operads”. Duke Math. J. 153 (2) 363 - 396, (2010).
- [GK] V. Ginzburg, M. Kapranov. “Koszul duality for operads”. Duke (1994).
- [Kel] B. Keller. “Introduction to A-infinity algebras and modules”. Homology, Homotopy and Applications, 3(1), 1-35 (2001).
- [KK] V. Kharitonov, K. Khoroshkin. “Gröbner Bases for Coloured Operads”. Annali di Matematica Pura ed Applicata (2021).
- [SU] S. Sanedidze, R. Umble. “Diagonals on the permutahedra, multiplihedra and associahedra”. Homology, Homotopy and Applications, 6(1), 363–411 (2004).
- [Sta] J. Stasheff. “Homotopy associativity of H-spaces. I, II”. Transactions of the American Mathematical Society, 108, 293–312 (1963).
- [T] D. Tamarkin. “What do dg-categories form?” Compositio Mathematica, 43(5), 1335 - 1358 (2007).

Chapter 5

Constrainahedra

5.1 Main definition

In this section, we introduce abstract posets $C(m, n)$ that we later show to be face posets of convex polytopes. These posets are closely related to 2-associahedra of Bottman [Bot1]. The name “constrainahedra” was communicated to the author by Bottman who was perhaps the first person to think of those polytopes; the author, however, had the sufficient algebraic motivation to go through the labour of giving the combinatorial definitions.

Our starting object is a configuration of n horizontal and m vertical lines:

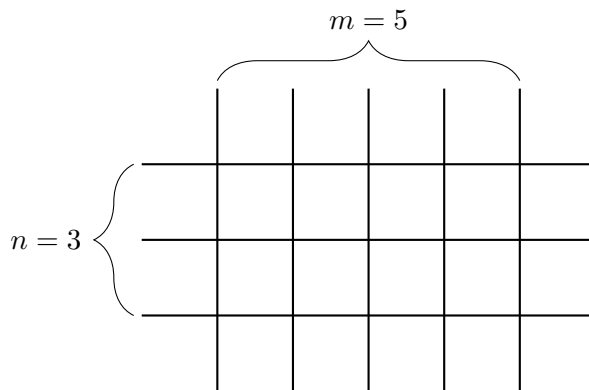

We combinatorially describe possible collisions of those lines, by introducing the notion of a good rectangular preorder and its associated rectangular bracketing.

5.1.1 Good rectangular preorders

We fix some notation. Let L_i be the horizontal lines and M_j be the vertical lines. Let $\text{Coll}(m, n)$ be the finite set consisting of elements m_i for $1 \leq i < m$

and l_i for $1 \leq j < n$. The element m_i will be formally called *the collision between lines M_i and M_{i+1}* , and the element l_j will be formally called *the collision between lines L_j and L_{j+1}* .

Our main heroes will be certain *preorders* on the set $\text{Coll}(m, n)$. Recall the following definition.

Definition 5.1.1. A *preorder* on a set X is a binary relation that is reflexive and transitive, but not necessarily anti-symmetric.

In an ordered set, two distinct elements can satisfy one of the following: $x < y$, $x > y$, or $x \# y$ (incomparable). In a preordered set, there is also a fourth possibility: $x \equiv y$ (corresponding to $x \leq y$ and $y \leq x$ both holding, which would be impossible for two distinct elements in an ordered set). We now say that x and y are comparable if $x < y$ or $x > y$ or $x \equiv y$.

We will deal with preorders on the set $\text{Coll}(m, n)$, called *rectangular preorders*. Let us fix the following terminology. Collisions m_i and l_j are *orthogonal*. Collisions m_i and $m_{i'}$ (or l_j and $l_{j'}$) are called *parallel*. For a fixed preorder, a collision l_s is called an *orthogonal link* between two parallel collisions m_i and m_j if $m_i \leq l_s \leq m_j$ (the definition of an orthogonal link between l_i and l_j is similar). A collision m_s is called a *gap* between two parallel collisions m_i and m_j if $s \in [i, j]$ and $m_i < s > m_j$ (the definition of a gap between l_i and l_j is similar). We are now ready to give the main definition.

Definition 5.1.2. A rectangular preorder is *good* if it satisfies:

1. (ORTHOGONAL COMPARABILITY) Orthogonal collisions are always comparable.
2. (PARALLEL COMPARABILITY) Parallel collisions are comparable if and only if at least one of the following holds:
 - there is an orthogonal link between them
 - there is no gap between them

Having a good rectangular preorder, we read $x < b$ as “collision x happened earlier than collision y ”, we read $x \equiv y$ as “collision x happened simultaneously with collision y ”, and we read $x \# y$ as “collision x happened far from collision y ” (so we have no idea which of them was first).

Example 5.1.3. This is a good rectangular preorder on the set $\text{Coll}(3, 5)$:

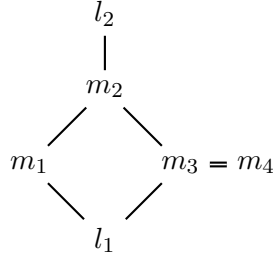

According to this preorder, in particular, m_2 happened earlier than l_2 , m_1 and m_3 happened far from each other, and m_3 and m_4 happened simultaneously.

For two rectangular preorders P_1 and P_2 , we say $P_1 \leq P_2$ if P_1 refines P_2 . Refinement means that if $x \leq_{P_1} y$ then $x \leq_{P_2} y$. If we view preorders as subsets of $\text{Coll}(m, n) \times \text{Coll}(m, n)$ consisting of pairs (x, y) such that $x \leq y$, then refinement corresponds to the opposite of inclusion.

We now introduce our main hero.

Definition 5.1.4. The constrainahedron $C(m, n)$ is the poset of good rectangular preorders on $\text{Coll}(m, n)$.

The constructed family of posets generalizes two known families.

Theorem 5.1.5. Posets $C(1, n) = C(n, 1)$ coincide with face posets of associahedra, and $C(2, n) = C(n, 2)$ coincide with face posets of multiplihedra.

Proof. To pass from $C(n, 1)$ to associahedra, use the labelling of faces by planar trees. Consider a planar tree with n leaves. To obtain a preorder on $\text{Coll}(n, 1)$, we associate to each l_i an inner vertex $v(l_i)$ located between leaves i and $i + 1$. Then we say $l_i \leq l_{i+1}$ if there is a descending path from $v(l_i) + v(l_{i+1})$. PARALLEL COMPARABILITY corresponds to inner vertices being comparable if and only if they belong to the same branch.

For the other direction, use the labelling of faces by bracketings of lines L_1, \dots, L_n . Having a good rectangular preorder, for each collision l_i add a bracket embracing the lines that have collided through collisions that happened earlier than l_i . PARALLEL COMPARABILITY ensures that these brackets are well-defined. The procedures described above are inverse to each other.

To compare $C(n, 2)$ with multiplihedra, consider some preorder on $\text{Coll}(n, 2)$. Restricting to $\text{Coll}(n, 2) \setminus \{m_1\}$ and forgetting the comparisons that existed due to an orthogonal link, we obtain a planar tree as explained above. But now for every inner vertex (corresponding to a collision l_i) we have an extra

piece of data: whether it happened before m_1 , simultaneously with m_1 or after m_1 (by ORTHOGONAL COMPARABILITY, all l_i are comparable to m_1). This gives the painting (recall that due to Forcey [For] faces of multiplihedra are represented by painted trees). \square

5.1.2 Anna & Bob metaphor for preorders

Informally, a good rectangular preorder corresponds to an account of a collision happening in discrete linear time, but with some data lost due to limitations of observation. Let us put an observer on each of the lines except for boundary lines, and additionally let us put an observer in each of the squares. For 2×4 case, we need two Annas to sit on M_2 and M_3 , and three Bobs to sit in the squares:

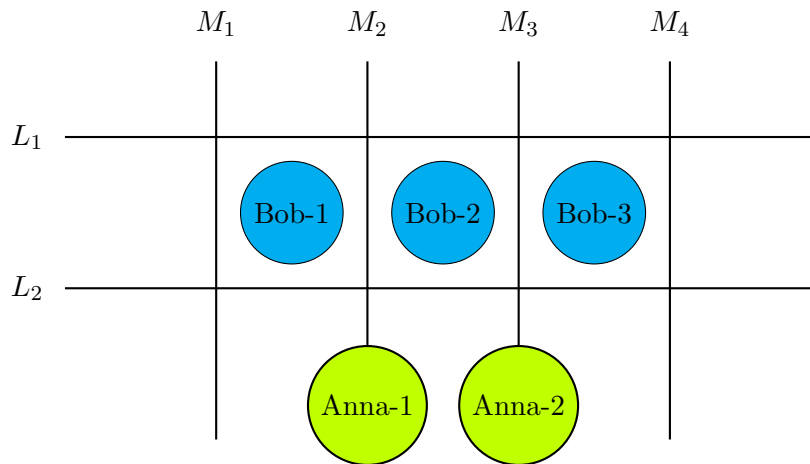

Assume that the observers only see things locally and can record events, but cannot keep track of time when nothing is happening. Let our team observe the following gradual collisions:

- In the first case, m_1 happens at moment 1, then l_1 happens at moment 2, then m_3 happens at moment 3 and finally m_2 happens in moment 4.
- In the second case, moment 1 and 2 change places.

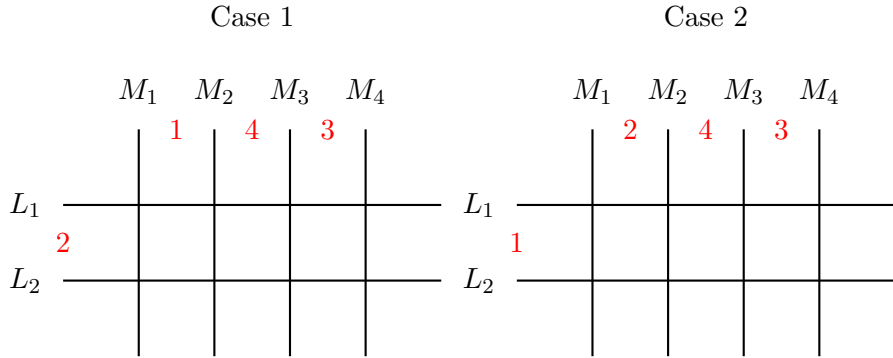

In each of the cases, let the team meet after the end of time, and discuss.

In case 1, Anna-1 knows that m_1 happened earlier than m_2 : sitting on M_2 , she saw M_1 earlier than she saw M_3 and met with Anna-2. Similarly, Anna-2 knows that m_3 happened earlier than m_2 . Together they are unable to compare m_1 with m_3 , but let Bobs join the discussion. Bob-1 knows that m_1 happened earlier than l_1 and Bob-3 knows that l_1 happened earlier than m_3 (the input from Bob-2 isn't needed). So together our observers can compare m_1 and m_4 through l_1 and come up with the correct (and full) account:



In case 2, Annas again agree that m_1 and m_3 were earlier than m_2 . However, at this time, the input from Bobs doesn't help the team to compare m_1 and m_3 : all Bobs simply tell that l_1 was earlier than everything else. So the final account is the following preorder:

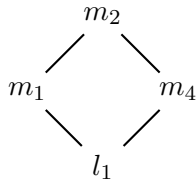

This Anna & Bob metaphor has something to do with realizing constraintahedra as Gromov compactifications, see [Bot2]. This will be written later.

5.1.3 Associated rectangular bracketings

Let a_{ij} be the intersection point of L_i and M_j , and let $A(m, n)$ be the set of all a_{ij} .

Definition 5.1.6. A rectangular bracket is a subset of $A(m, n)$ of the form $\{a_{i,j} | i_s \leq i \leq i_t, j_s \leq j \leq j_t\}$.

To a good rectangular preorder P , we associate a collection of rectangular brackets $Br(P)$, called a rectangular bracketing.

Definition 5.1.7. A bracket $\{a_{i,j} | i_s \leq i \leq i_t, j_s \leq j \leq j_t\}$ is added to $Br(P)$ if, according to P , all of the collisions l_i for $i_s \leq i < i_t$ and m_j for $j_s \leq j < j_t$ happened earlier than l_{i_s-1} , i_{i_t} , m_{j_s-1} and m_{j_t} (if one of those is not defined, it is assumed to happen *never*, which is later than anything).

Informally this means that a bracket embraces items that collide at each moment of time.

Example 5.1.8. For the preorder in Example 5.1.3, its associated rectangular bracketing is this:

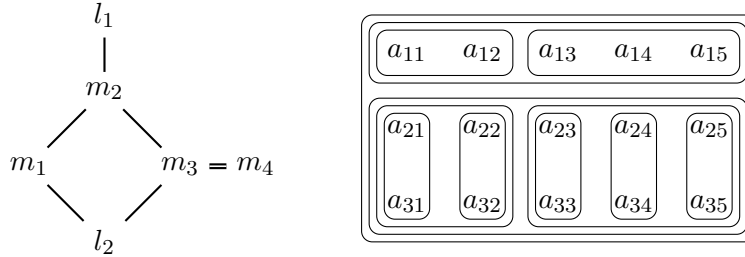

For example, the bracket embracing a_{21} , a_{22} , a_{31} and a_{32} was added because the collisions l_2 and m_1 were all earlier than l_1 and m_2 (and certainly earlier than *never*).

The assignment $P \mapsto Br(P)$ gives a map from good rectangular preorders to sets of subsets of $A(m, n)$:

$$Br : C(m, n) \rightarrow 2^{2^{A(m, n)}}$$

Theorem 5.1.9. Br is injective: the associated rectangular bracketing keeps all the data of a good rectangular preorder.

Proof. We explain how the data of P can be restored from $Br(P)$. First consider two orthogonal collisions, l_i and m_j . Look at the intersections $a_{i,j}$, $a_{i,j+1}$, $a_{i+1,j}$ and $a_{i+1,j+1}$. There are three possibilities:

1. $Br(P)$ has brackets R_1, R_2 such that $a_{i,j}$ and $a_{i,j+1}$ are in R_1 and not in R_2 , while $a_{i+1,j}$ and $a_{i+1,j+1}$ are in R_2 and not in R_1 . In this case $l_i <_P m_j$.

2. $Br(P)$ has brackets R_1, R_2 such that $a_{i,j}$ and $a_{i+1,j}$ are in R_1 and not in R_2 , while $a_{i,j+1}$ and $a_{i+1,j+1}$ are in R_2 and not in R_1 . In this case $l_i >_P m_i$.
3. Every bracket of $Br(P)$ that has $a_{i,j}$ also has $a_{i+1,j+1}$. In this case $l_i \equiv m_j$.

Now consider two parallel collisions, l_i and l_j , for $i < j$ (for m_i and m_j the argument is identical). If they were comparable through existence of a link, this data is restored by transitivity. For comparability through the absence of gaps, check which of the following four possibilities holds:

1. $Br(P)$ has two brackets $R_1 \subset R_2$ such that R_1 contains $a_{i,1}$ and $a_{i+1,1}$ but not $a_{j+1,1}$, and R_2 contains $a_{j+1,1}$. In this case $l_i < l_j$.
2. $Br(P)$ has two brackets $R_1 \subset R_2$ such that R_1 contains $a_{j,1}$ and $a_{j+1,1}$ but not $a_{i,1}$, and R_2 contains $a_{i,1}$. In this case $l_i > l_j$.
3. $Br(P)$ has a bracket that contains $a_{i,1}$ and $a_{j+1,1}$, and for every $R' \subset R$ the same holds. In this case $l_i \equiv l_j$.
4. None of the above; in this case either they l_i and l_j are comparable via an orthogonal link, or incomparable.

□

Therefore, rectangular bracketings can be used as a convenient visualization of preorders.

Remark 5.1.10. When looking at a collection of rectangular brackets, it might be not immediately obvious whether this collection is associated to a preorder. For example, the reader might check that the following collection is not.

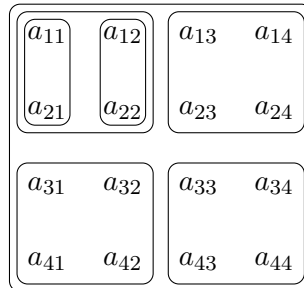

Example 5.1.11. Below is $C(2, 3)$ in terms of rectangular bracketings, suggestively laid over a hexagon.

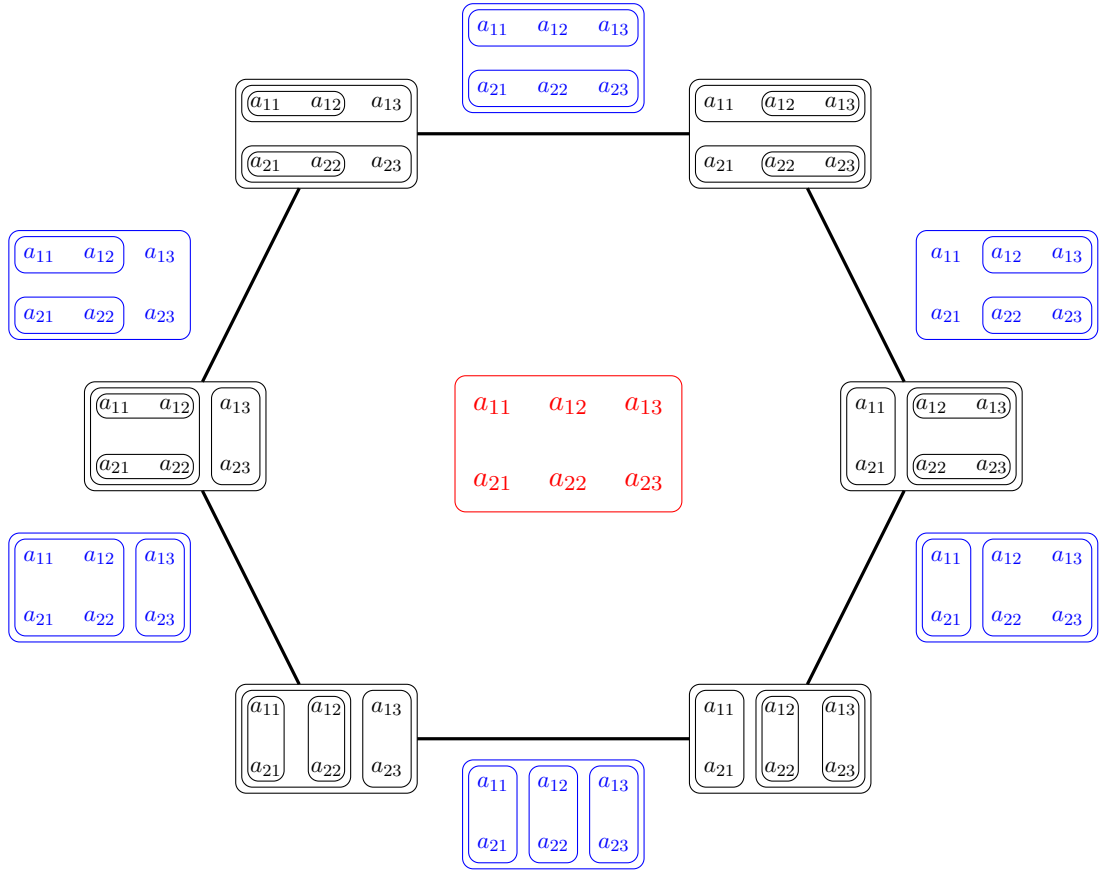

5.2 Constraintahedra are lattices

We now proceed by proving $C(m, n)$ are lattices. We will further show that they are not only lattices, but actually face posets of embedded polytopes; proving the lattice property abstractly is needed to make use of the fact that polytopes are determined by their vertex-facet incidences.

Lemma 5.2.1. For a parallel comparison $m_i \leq m_j$ in some good rectangular preorder P , we have $m_s \leq m_j$ for every $s \in [i, j]$.

Proof. We need to show that m_s cannot be incomparable to m_j . Assume the contrary; then there exists a gap m_k with $k \in [s, j]$ and $m_k > m_j$. But $[s, j] \subset [i, k]$, so m_k is also a gap between m_i and m_j , which contradicts their comparability. \square

Lemma 5.2.2. Let P and Q be two good rectangular preorders, viewed as subsets in $\text{Coll}(m, n) \times \text{Coll}(m, n)$. Let $\overline{P \cup Q}$ denote the transitive closure of $P \cup Q$. Then $\overline{P \cup Q}$ is also good rectangular preorder.

Proof. ORTHOGONAL COMPARABILITY is satisfied trivially: orthogonal collisions are comparable in each of the preorders, so certainly in their union and in its transitive closure.

PARALLEL COMPARABILITY requires more work. First assume that for two parallel collisions there exists a $\overline{P \cup Q}$ -link. Then they are comparable by transitivity of $\overline{P \cup Q}$. Now assume that for two parallel collisions (without loss of generality call them m_i and m_j) there are no $\overline{P \cup Q}$ -gaps between them.

If this is due to absence of gaps in P or in Q , then comparability follows from the axioms on P or Q . So assume that both P and Q have a gap between m_i and m_j . Let m_s be such a gap in P : $m_i <_P m_s >_P m_j$. The fact that this gap disappears in $\overline{P \cup Q}$ means that one of strict inequalities becomes an equivalence: either $m_i \geq_{\overline{P \cup Q}} m_s$ or $m_j \geq_{\overline{P \cup Q}} m_s$. In the first case, we have $m_i \geq_{\overline{P \cup Q}} m_s >_P m_j$, and in the second case we have $m_i <_P m_s \leq_{\overline{P \cup Q}} m_j$ – in both cases this gives a $\overline{P \cup Q}$ -comparability, because $\overline{P \cup Q}$ is transitive and refines P .

In the other direction: assume that for two parallel collisions m_i and m_j that there are no $\overline{P \cup Q}$ -links and a $\overline{P \cup Q}$ -gap m_s . We must show that they cannot be $\overline{P \cup Q}$ -comparable.

Assume the contrary – that they are $\overline{P \cup Q}$ -comparable, which means that there exists a chain $m_i = x_0 \leq x_1 \leq \dots \leq x_p = m_j$, where each of inequalities $x_a \leq x_{a+1}$ holds either in P or in Q . Firstly we notice that none of x_k can be orthogonal to m_i and m_j : this would give an orthogonal link. This means that each of $x_a \leq x_{a+1}$ is a parallel comparison of m 's which happens due to absence of gaps. We now recall our m_s , a $\overline{P \cup Q}$ -gap. Consider the step $x_a \leq_P x_{a+1}$ over m_s . Then we have $x_{a+1} \geq_P m_s$ by Lemma 5.2.1, and $x_{a+1} \geq_P m_s >_{\overline{P \cup Q}} m_j$ contradicts $x_{a+1} \leq_{\overline{P \cup Q}} m_j$. \square

Lemma 5.2.3. Let P and Q be two good rectangular preorders. Assume that $P \cap Q$ satisfies ORTHOGONAL COMPARABILITY, and absence of gaps implies parallel comparability. Then $P \cap Q$ is a good rectangular preorder.

Proof. We are left to check the converse: that parallel comparability implies that there is either an orthogonal link or no gaps. Assume the contrary: that there are two parallel collisions $m_i \leq_{P \cap Q} m_j$ such that there is a gap and no link between them. We notice that absence of link in $P \cap Q$ means that there was no link both in P and in Q : $P \cap Q$ can only satisfy ORTHOGONAL COMPARABILITY if all orthogonal comparisons coincide in P and in Q . So $m_i \leq_P m_j$ means that there is no gap in P and $m_i \leq_Q m_j$ means that there

is no gap in Q . Now consider m_s which is a $P \cap Q$ -gap between m_i and m_j . Since $m_s \geq m_j$ holds in $P \cap Q$, it must also hold both in P and in Q , so the only chance for m_s not to be a P -gap is $m_s \equiv_P m_j$, and the only chance for m_s not to be a Q -gap is $m_s \equiv_Q m_j$. But then $m_s \equiv_{P \cap Q} m_j$, which contradicts to it being a gap. \square

Theorem 5.2.4. The poset $C(m, n) \coprod \{-1\}$ is a lattice.

Proof. Let P and Q be two good rectangular preorders. The existence of their join in $C(m, n)$ follows from Lemma 5.2.2: $\overline{P \cup Q}$ is the join of P and Q among all the rectangular posets, so certainly among good ones.

For their meet, check if $P \cap Q$ (the meet of P and Q among all preorders) is good. If it is, then this is the meet. Otherwise the meet is -1 . For this to be true, we need to verify that if $P \cap Q$ is not good, then there is no good preorder refined by it.

Assume the contrary. By Lemma 5.2.3, failure to be good means either lack of orthogonal comparability or lack of parallel comparability for a pair with no gap. Lack of orthogonal comparability cannot be rectified by further coarsening. So let $m_i \#_{P \cap Q} m_j$ be an incomparable parallel pair with no $P \cap Q$ -gap. Rectification by coarsening would mean creating this gap, by replacing one or two equivalences by strict inequalities, $m_i \equiv m_s \equiv m_j \implies m_i < m_s > m_j$ or $m_i \equiv m_s > m_j \implies m_i < m_s > m_j$ – but in both cases we see that m_i and m_j are already comparable in $P \cap Q$. \square

Lattices are determined by interactions between meet-irreducibles (also called atoms or vertices) and join-irreducibles (also called coatoms or facets). In case of $C(m, n)$, both sets are easy to describe. Vertices are preorders where equivalence implies equality – so the number of equivalence classes is $c + m - 2$, and preorders are actually posets. Facets are preorders where the number of equivalence classes is 2.

Additionally we will speak of *edges*: preorders where the number of equivalence classes is $c + m - 2$, meaning that there is exactly one class consisting of 2 simultaneous collisions. For the next section, we need some understanding of edge-connectedness.

Lemma 5.2.5. Any two vertices of $C(m, n)$ are connected by a sequence of edges.

Proof. Passing from one vertex to another by an edge means swapping the collisions on two sides of an edge in the Hasse diagram of the corresponding poset, and then removing illegitimate parallel comparisons if they appear. Let v and w be two vertices that we want to connect. We first consider minimal elements of w and apply swaps to v until they the corresponding

collisions are w -placed. At every next step, we w -place the collisions for whom their lower w -neighbours have already been w -placed. Since every swap does not affect the collisions that have already been w -placed, the procedure only terminates when the target vertex has been reached. \square

Example 5.2.6. Let v and w be the following vertices of $C(3, 2)$:

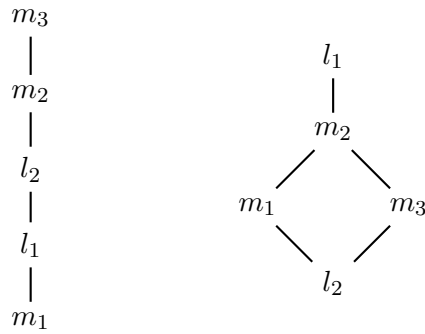

The minimal element of w is l_2 , and the edge subsequence that starts at v and w -places l_2 is the following:

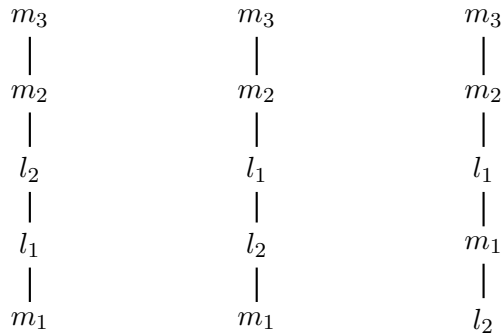

Now the lower w -neighbours of m_1 and m_3 are w -placed. It happens that m_1 is w -placed as well. Edge subsequence w -placing m_3 is as follows:

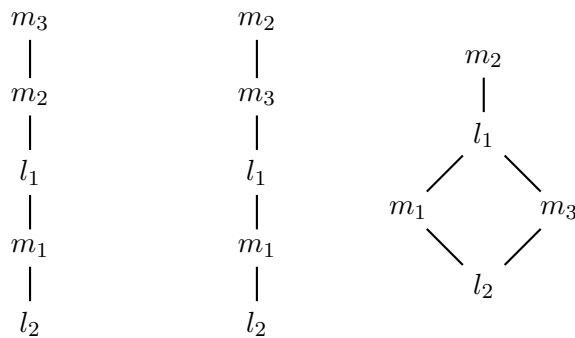

Now all lower w -neighbours of m_2 have been w -placed, and the subsequent w -placing m_2 consists of one egde:

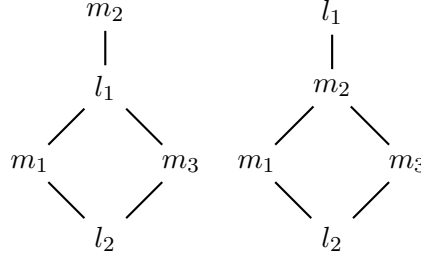

Lemma 5.2.7. Any two vertices inside one facet of $C(m, n)$ are connected by a sequence of edges within that facet.

Proof. A facet F is given by two equivalence classes, $C_1 <_F C_2$. A vertex v belongs to F if and only if for every $x \in C_1$ and $y \in C_2$ we have $x <_v y$. For two vertices satisfying this, the algorithm explained in the proof of Lemma 5.2.5 never requires to swap collisions from C_1 and C_2 , so the edge sequence stays within F . \square

5.3 Convex hull realization

We now provide an explicit polytopal realization of constrainahedra, by giving formulas for vertex coordinates.

Fix a vertex $v \in C(m, n)$. To this vertex, we will assign *horizontal* coordinates x_1, \dots, x_{n-1} (with x_i corresponding to the collision l_i), and *vertical* coordinates y_1, \dots, y_{m-1} (with y_j corresponding to the collision m_j).

Every coordinate (no matter horizontal or vertical) will be obtained as a product of three natural numbers: $W_1 \times W_2 \times T$, where W_1 is called *first weight*, W_2 is called *second weight* and T is called *thickness*.

To give the definitions of those numbers, we need some additional terminology.

Definition 5.3.1. A partial binary bracketing (PBB) is an arrangement of brackets obtained from a binary bracketing by removing some brackets in such a way that every remaining bracket is binary.

For example, $ab(cd)$ and $((ab)(cd))$ are PBB, and $(ab(cd))$ is not a PBB.

Definition 5.3.2. The thickness of a PBB is the number of pairs (a_i, a_j) such that there exists a bracket embracing (at any depth) both a_i and a_j , plus 1.

In the examples above, $ab(cd)$ has weight 2 with the only such pair being (c, d) , and $((ab)(cd))$ has weight $7 = 1 + \binom{4}{2}$, because every pair of letters is embraced by some bracket.

Now we define agglomerations of lines.

Definition 5.3.3. For a collision l_i , the agglomeration $|\text{Ag}_{l_i}(L_i)|$ of L_i consists of lines that have collided with L_i earlier than l_i , and the agglomeration $|\text{Ag}_{l_i}(L_{i+1})|$ of L_{i+1} consists of lines that have collided with L_{i+1} earlier than l_i . Agglomerations for collisions m_j are defined similarly.

Now let x_i be a horizontal coordinate of v , corresponding to the collision l_i . We set $W_1 = |\text{Ag}_{l_i}(L_i)|$ and $W_2 = |\text{Ag}_{l_i}(L_{i+1})|$. Finally, T is the thickness of the PBB whose elements are lines M_j and whose brackets come from vertical collisions that happened before l_i .

Similarly, let y_j be a vertical coordinate, corresponding to the collision m_j . We set $W_1 = |\text{Ag}_{m_j}(M_j)|$ and $W_2 = |\text{Ag}_{m_j}(M_{j+1})|$. Finally, T is the thickness of the PBB whose elements are lines L_i and whose brackets come from horizontal collisions that happened before m_j .

For every vertex v , we will shortly denote the point with coordinates x_i and y_j by $(x, y)_v$.

Example 5.3.4. Consider the following vertex:

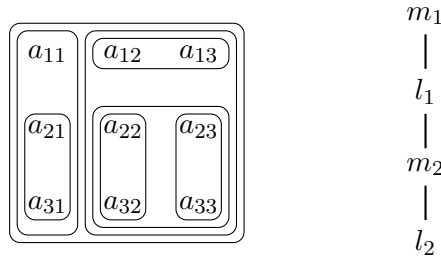

We compute the coordinates by the procedure explained above.

1. For x_1 , we have l_1 , l_2 and m_2 that happened earlier than m_1 . So $W_1 = 1$ because $\text{Ag}_{m_1}(M_1) = \{M_1\}$, $W_2 = 2$ because $\text{Ag}_{m_1}(M_2) = \{M_2, M_3\}$ by m_2 , and $T = 1 + \binom{3}{2} = 4$ because the horizontal PBB is $(L_1(L_2L_3))$ by l_1 and l_2 , with every pair contributing to thickness. So $x_2 = 1 \times 2 \times 4 = 8$.
2. For x_2 , we have l_2 that happened earlier than m_2 . So $W_1 = 1$ because $\text{Ag}_{m_2}(M_2) = \{M_2\}$, $W_2 = 1$ because $\text{Ag}_{m_2}(M_3) = \{M_3\}$, and $T =$

$1 + 1 = 2$ because the horizontal PBB is $L_1(L_2L_3)$ with (L_2, L_3) being the pair that collided through l_2 and contributes to thickness. Thus $x_2 = 1 \times 1 \times 1 = 2$.

3. For y_1 , we have l_2 and m_2 that happened earlier than l_1 . So $W_1 = 1$ because $\text{Ag}_{l_1}(L_1) = \{L_1\}$, $W_2 = 2$ because $\text{Ag}_{l_1}(L_2) = \{L_2, L_3\}$ by l_2 , and $T = 1 + 1 = 2$ because the vertical PBB is $M_1(M_2M_3)$ with (M_2, M_3) being the pair that collided through m_2 and contributes to thickness. Thus $y_1 = 1 \times 2 \times 2 = 4$.
4. For y_2 , we have no collision that happened earlier than l_2 . So $W_1 = 1$ because $\text{Ag}_{l_2}(L_2) = \{L_2\}$, $W_2 = 1$ because $\text{Ag}_{l_2}(L_3) = \{L_3\}$, and $T = 1$ because the vertical PBB is $M_1M_2M_3$ with no brackets. Thus $y_2 = 1 \times 1 \times 1 = 1$.

Thus $(x, y)_v = (8, 2, 4, 1)$.

Our main result is the following theorem:

Theorem 5.3.5. Convex hulls of $(x, y)_v$ for vertices $v \in C(n, m)$ are polytopes whose face posets are isomorphic to $C(n, m)$.

The proof consists of several lemmas.

Lemma 5.3.6. For any $v \in C(n, m)$, the point $(x, y)_v$ lays in the hyperplane

$$\sum x_i + \sum y_j = \binom{n}{2} \binom{m}{2} + \binom{n}{2} + \binom{m}{2}$$

Proof. We first show that the equality holds for a certain vertex v_0 with most computable coordinates, and then show that the sum of all coordinates doesn't change along an edge.

Let v_0 be a vertex with poset $l_1 < \dots < l_{n-1} < m_1 < \dots < m_{m-1}$ (first all horizontal lines are collapsed, left to right, then all vertical lines are collapsed, top to bottom). Then the horizontal coordinates are $1, 2, \dots, m$ (all computed with thickness 1) and vertical coordinates are $1 \times \binom{m}{2} + 1, 2 \times \binom{m}{2} + 1, \dots, n \times \binom{m}{2} + 1$ (all computed with thickness precisely $\binom{m}{2} + 1$). So the sum is indeed

$$(1 + \dots + m) + (1 + \dots + n) \left(\binom{m}{2} + 1 \right) = \binom{n}{2} \binom{m}{2} + \binom{n}{2} + \binom{m}{2}$$

Now recall Lemma 5.2.5. Let E be some edge. It corresponds to a preorder where some equivalence class C has cardinality 2. There are three possibilities:

1. $C = \{l_a, l_b\}$ and $l_i < l_a \equiv l_b$ for $a < i < b$ (by PARALLEL COMPARABILITY)

2. $C = \{m_a, m_b\}$ and $m_i < m_a \equiv m_b$ for $a < i < b$ (by PARALLEL COMPARABILITY)
3. $C = \{l_a, m_b\}$, with no conditions.

For an edge of type 1, let v be its endpoint with $l_a < l_b$ and let w be its endpoint with $l_a > l_b$. Then v and w only differ in two horizontal coordinates x_a and x_b . We notice that the thickness of the vertical PBB is the same for l_a and l_b , no matter in which order they collide; we denote this quality by T . For v , let denote $|\text{Ag}_{l_a}(L_a)|$ by A , and for w , denote $|\text{Ag}_{l_b}(L_{b+1})|$ by B . In this notation, for v we have

$$\begin{aligned}x_a(v) &= A \times (b - a) \times T \\x_b(v) &= (A + (b - a)) \times B \times T\end{aligned}$$

and for w we have

$$\begin{aligned}x_a(w) &= A \times ((b - a) + B) \times T \\x_b(w) &= (b - a) \times B \times T\end{aligned}$$

For both vertices, the sum of the two coordinates is equal to

$$(A \times (b - a) + A \times B + (b - a) \times B) \times T$$

For an edge of type 2, the argument is the same.

Finally, for an edge of type 3, let v be its endpoint with $l_a < m_b$, and let w be its endpoint with $l_a > m_b$. Then v and w only differ in coordinates x_a and y_b . Let T_{vert} be the thickness of the vertical PBB by the time of collision l_a in v , and let T_{hor} be the thickness of the horizontal PBB by the time of collision m_b in w . We notice that $|\text{Ag}_{l_a}(L_a)|$ and $|\text{Ag}_{l_a}(L_{a+1})|$ are the same for v and w ; denote these qualities by A_1 and A_2 . Similarly, we notice that $|\text{Ag}_{m_b}(M_b)|$ and $|\text{Ag}_{m_b}(M_{b+1})|$ are the same for v and w ; denote these qualities by B_1 and B_2 . In this notation, for v we have

$$\begin{aligned}x_a(v) &= A_1 \times A_2 \times T_{\text{vert}} \\y_b(v) &= B_1 \times B_2 \times (T_{\text{hor}} + A_1 \times A_2)\end{aligned}$$

and for w we have

$$\begin{aligned}x_a(w) &= A_1 \times A_2 \times (T_{\text{vert}} + B_1 \times B_2) \\y_b(w) &= B_1 \times B_2 \times T_{\text{hor}}\end{aligned}$$

For both vertices, the sum of the two coordinates is equal to

$$A_1 \times A_2 \times T_{\text{vert}} + A_1 \times A_2 \times B_1 \times B_2 + B_1 \times B_2 \times T_{\text{hor}}$$

□

To formulate the next Lemma, we need to classify facets of $C(m, n)$. Recall that a facet is good rectangular preorder with two equivalence classes, C_1 and $C_2 = C(m, n) \setminus C_1$. For ORTHOGONAL COMPARABILITY and PARALLEL COMPARABILITY to be satisfied, C_1 can be one of the following:

1. $C_1 = \{l_i | i \in I\}$ where $I \subset [1, n - 1]$ is a subinterval not equal to all of $[1, n - 1]$
2. $C_1 = \{m_j | j \in J\}$ where $J \subset [1, m - 1]$ is a subinterval not equal to all of $[1, m - 1]$
3. $C_1 = \{l_i, m_j | i \in \bigcup_s I_s, j \in \bigcup_t J_t\}$ where I_s are subintervals of $[1, n - 1]$ satisfying $\max I_s < \min I_{s+1}$ and J_t are subintervals of $[1, m - 1]$ satisfying $\max J_t < \min J_{t+1}$

We say that corresponding facets are of Types 1, 2 and 3 accordingly.

Lemma 5.3.7. Let $F \in C(n, m)$ be facet of Type 1 with $C_1 = \{l_i | i \in I\}$. Denote $a = |I| + 1$. Then for every vertex v in F we have

$$\sum_{i \in I} x_i = \binom{a}{2}$$

For vertex w outside F we have

$$\sum_{i \in I} x_i > \binom{a}{2}$$

Proof. Just as in the previous case, we first verify the equality for a vertex whose coordinates are most computable. Set $r = \min I$, and let v be the vertex with corresponding to the following order where l 's happen left to right first inside C_1 , then inside C_2 , and then m 's happen top to bottom: formally, $l_a < l_b$ either in one of the three cases: $a \in I$ and $b \notin I$, or $a, b \in I$ and $a < b$, or $a, b \notin I$ and $a < b$; $l_a < m_b$ always; and $m_a < m_b$ when $a < b$. Then the collisions contributing to the coordinates x_i for $i \in I$ all happen with thickness 1, and they are equal to 1, 2, ..., a , proving the equality for v . To see that the equality holds for any vertex of F , we recall Lemma 5.2.7, consider an edge within F and notice that the coordinate change described in the proof of Lemma 5.3.6 happens only among x_i with $i \in I$, thus not affecting $\sum_{i \in I} x_i$.

To prove the inequality, let w be some vertex outside F . Being outside F means that there is a collision c that happened earlier than all the collisions of C_1 . This collision contributes to some agglomeration size or some thickness among the coordinates coming from collisions of C_1 . Thus it makes $\sum_{i \in I} x_i$ strictly greater in w than in a vertex of F given by restricting the preorder of w to C_1 , and then ordering other collisions arbitrarily. \square

Lemma 5.3.8. Let $F \in C(n, m)$ be facet of Type 2 with $C_1 = \{m_i | j \in J\}$. Denote $b = |J| + 1$. Then for every vertex $v < F$ we have

$$\sum_{j \in J} y_j = \binom{b}{2}$$

Furthermore, for any vertex v incomparable with F we have

$$\sum_{j \in J} y_j > \binom{b}{2}$$

Proof. The proof is identical to the proof of the previous lemma. \square

Lemma 5.3.9. Let $F \in C(n, m)$ be facet of Type 3 with $C_1 = \{l_i, m_j | i \in \cup_s I_s, j \in \cup_t J_t\}$. Denote $a_s = |I_s| + 1$ and $b_t = |J_t| + 1$. Then for every vertex $v < F$ we have

$$\sum_{i \in \cup_s I_s} x_i + \sum_{j \in \cup_t J_t} y_j = \sum_s \binom{a_s}{2} + \sum_t \binom{b_t}{2} + \sum_{s,t} \binom{a_s}{2} \binom{b_t}{2}$$

Furthermore, for any vertex v incomparable with F we have

$$\sum_{i \in \cup_s I_s} x_i + \sum_{j \in \cup_t J_t} y_j > \sum_s \binom{a_s}{2} + \sum_t \binom{b_t}{2} + \sum_{s,t} \binom{a_s}{2} \binom{b_t}{2}$$

Proof. Just as in the previous case, we first verify the equality for a vertex whose coordinates are most computable. Set $r_s = \min I_s$, $q_t = \min J_t$ and again let v be the vertex with corresponding to the order where l 's happen left to right first inside C_1 , then inside C_2 , then other l 's happen left to right, then other m 's happen top to bottom. Formally this means that for l_i and l_j , $l_i < l_j$ holds in one of the following cases: $i, j \in I_s$ for some s , and $i < j$, or $i \in \cup_s I_s$ and $j \notin \cup_s I_s$, or $i, j \notin \cup_s I_s$ and $i < j$. Parallel comparisons between m 's are identical. For l_i and m_j , $l_i > m_j$ holds if $i \notin \cup_s I_s$ and $j \in \cup_t J_t$. Then the collisions contributing to the coordinates x_i for $i \in I_s$ all happen with thickness 1, and they are equal to $1, 2, \dots, a_s$. Collisions contributing to the coordinates y_j for $k \in J_t$ happen with thickness $\sum_s \binom{a_s}{2}$, and their weight products are equal to $1, 2, \dots, b_t$. This proves the equality for v . To see that the equality holds for any vertex of F , we recall Lemma 5.2.7, consider an edge within F and notice that the coordinate change described in the proof of Lemma 5.3.6 happens only among the coordinates featured in the above sum, thus not affecting it. \square

This finishes the proof of the theorem.

Remark 5.3.10. For associahedra, the embedding presented in this section is the classical Loday embedding [Lod]. For multiplihedra, the embedding presented in this section is the classical Forcey embedding [For] for $q = 1/2$, scaled by 2.

Bibliography

- [Bot1] N. Bottman. “2-associahedra”. *Algebraic and Geometric Topology*, (2019).
- [Bot2] N. Bottman. “Moduli spaces of witch curves topologically realize the 2-associahedra”, *Journal of Symplectic Geometry*, 17(6), (2019).
- [For] S. Forcey. “Convex Hull Realizations of the Multiplihedra”. *Topology and its Applications*, 56(2), 326-347 (2008).
- [Lod] J.-L. Loday. “Realization of the Stasheff polytope”, *Archiv der Mathematik*, 83, 267–278 (2004)

